

E P2E Choke 5CB

10 000 psig / Max Cv 27 / Max Bean Size 81

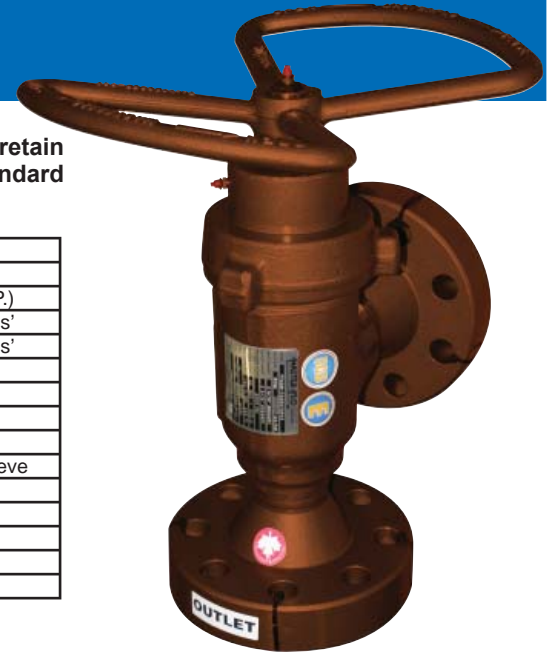

VALVE SPECIFICATIONS

Valve Model	P2E
Body Type	Right Angle
Body Rating	10 000 PSIG (Maximum C.W.P.)
Inlet Connection	see 'Standard End Connections'
Outlet Connection	see 'Standard End Connections'
Bonnet Type	Hammer-Union Nut
Body / Bonnet Material	see 'Material Options'
Stem Material	see 'Material Options'
Seal Material	see 'Material Options'
Trim Style	Ported Cage with External Sleeve
Balanced / Unbalanced	Semi-Balanced
Flow Characteristic	Equal Percentage
Trim Material	see 'Trim Options'
Design Cv	see 'Trim Options'
Leakage Class	Class V (Standard)

TRIM OPTIONS

	Standard Trim Cage & External Sleeve 2 Row / 4 Hole	Multistage Trim	High-Pressure Multi-stage Trim
Material	UNS S17400, Stellite, Tungsten Carbide	Stellite, Tungsten Carbide	Stellite, Tungsten Carbide
Application	Liquid, Gas, Multiphase; Abrasive	Liquid, Gas, Multiphase	Liquid, Gas, Multiphase
Cv	27	7	6
Turns	11	8	8
Travel	1.35"	1.00"	1.00"

STANDARD END CONNECTIONS

Connection Size ▶	Standard Dimensions & Estimated Weights											
	2" Nominal				2-1/2" Nominal				3" Nominal			
	'I' or 'O'		Weight		'I' or 'O'		Weight		'I' or 'O'		Weight	
Connection Type ▼	inch	mm	lbs.	kg	inch	mm	lbs.	kg	inch	mm	lbs.	kg
Threaded	4.50	114	82	37	n/a	n/a	n/a	n/a	n/a	n/a	n/a	n/a
ASME 150 RF	7.00	178	92	42	7.25	184	101	46	7.25	184	103	47
ASME 300 RF	7.25	184	96	44	7.50	191	106	48	7.62	194	114	52
ASME 600 RF	7.62	194	100	45	7.88	200	110	50	8.00	203	116	53
ASME 600 RTJ	7.69	195	100	45	7.94	202	110	50	8.06	205	116	53
ASME 900 RF	8.75	222	128	58	8.88	225	149	68	8.75	222	138	63
ASME 900 RTJ	8.81	224	128	58	8.94	227	149	68	8.81	224	138	63
ASME 1500 RF	8.75	222	128	58	8.88	225	149	68	9.38	238	176	80
ASME 1500 RTJ	8.81	224	128	58	8.94	227	149	68	9.44	240	176	80
ASME 2500 RTJ	9.81	249	164	74	10.50	267	191	87	11.50	292	268	122
2 000 API 6B	7.69	195	100	45	7.94	202	110	50	8.06	205	116	53
3 000 API 6B	8.81	224	128	58	8.94	227	149	68	8.81	224	138	63
5 000 API 6B	8.81	224	124	56	8.94	227	149	68	9.44	240	176	80
10 000 API 6BX	8.81	224	124	56	9.38	238	148	67	10.75	273	230	104

ENVELOPE DIMENSIONS

Dimensions 'A', 'B', and 'C' apply to manually operated chokes and are tabulated below. 'I' (inlet) and 'O' (outlet) dimensions depend on the end connections and are tabulated above. Special dimensions and other end connections are available upon request.

Dimensions		
	inch	mm
A	13.00	330
B	18.00	457
C	18.88	479

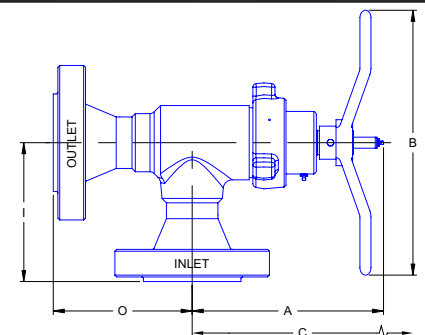

Note: "C" is the disassembly clearance.

MATERIAL OPTIONS

Temperature Class	Certification Level	API - 6A Material Class Designations						
		AA	BB	CC	DD	EE	FF	HH
PU -20F to 250F	STD / PSL-1	BB	BB	FF	EE	EE	FF	HH
PX -20F to 350F	PSL-2	EE	EE	FF	EE	EE	FF	HH
	PSL-3	EE	EE	FF	EE	EE	FF	HH
LU -50F to 250F	STD / PSL-1	EE	EE	FF	EE	EE	FF	HH
PX -50F to 350F	PSL-2	EE	EE	FF	EE	EE	FF	HH
	PSL-3	EE	EE	FF	EE	EE	FF	HH

	BB-General Service	EE-Sour Service	FF-Sour Service	HH-Sour Service
Body	AISI 8620	AISI 8620	UNS S31803	AISI 8620 / Inconel 625
Bonnet	ASTM A350 LF2 or AISI 4130	ASTM A350 LF2 or AISI 4130	UNS S31803	Inconel 625
Stem	UNS S17400	UNS S17400	UNS S17400	Inconel 718
Bolting	AISI 4130	AISI 4130	AISI 4130	AISI 4130
Retaining Sleeve	ASTM A743 CF8M	ASTM A743 CF8M	ASTM A743 CF8M	Inconel 625
Seals	Buna - N	Viton	Viton	Teflon

Other materials available upon request.

OTHER VALVE OPTIONS

	Standard	Optional
Calibration Head / Serial Plaque	Aluminum	Stainless Steel
Outlet Sleeve	-	Stainless Steel, Tungsten Carbide
Body Bleed Port	-	½" NPT, API Autoclave

Some limitations may apply.

ACTUATION OPTIONS

Master Flo	Other
Manually Operated (Stemlock is optional)	Pneumatic Diaphragm
FC Hydraulic Piston	Pneumatic Piston
Pneumatic Piston	Electric

Other actuators available upon request.

PERFORMANCE CHARACTERISTICS

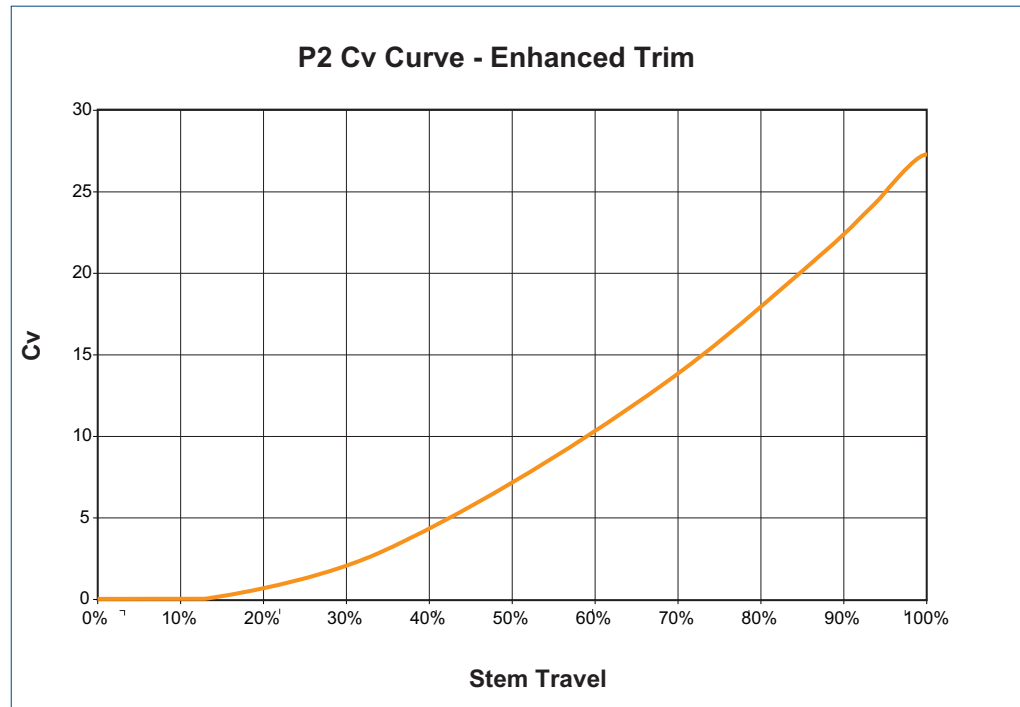

LIQUID PRESSURE RECOVERY FACTOR (FL)

Master Flo's trim geometry has been designed to achieve high F_L numbers. This results in a decreased cavitation potential, lower noise generation, increased flow capacity, and longer trim life. The high F_L numbers of Master Flo's trims have been verified experimentally as per the test procedures of ISA-S75.02-1996.

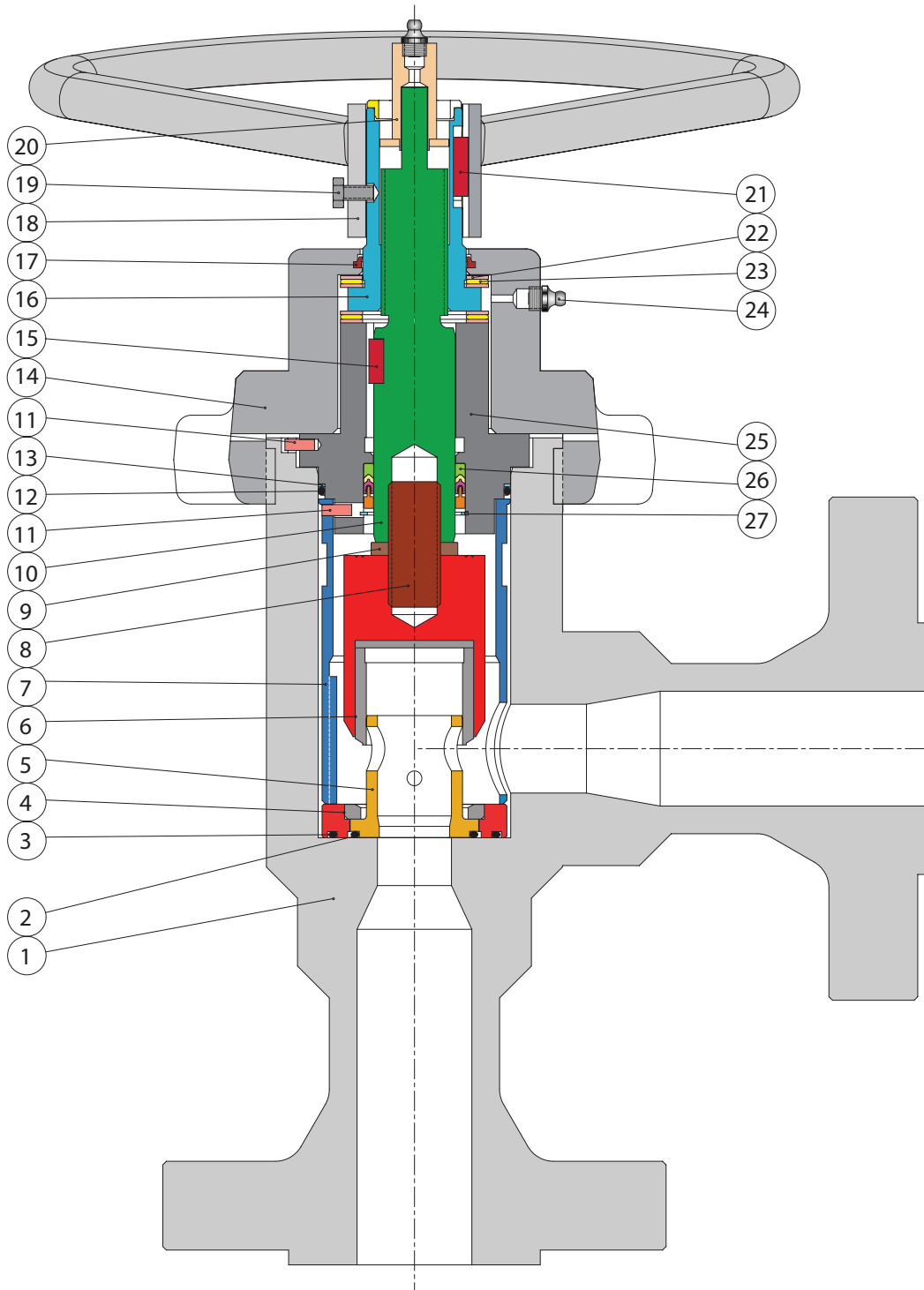

PARTS LIST

1. Body
2. Seal: Cage - Body
3. Seal: Seat - Body
4. Seat
5. Cage
6. External Sleeve
7. Retaining Sleeve
8. Stud
9. Lockwasher
10. Stem
11. Pin
12. Seal: Bonnet - Body
13. B/U Ring: Bonnet - Body
14. Bonnet Nut
15. Key
16. Stem Nut
17. Wiper
18. Handwheel
19. Capscrew
20. Calibration Head
21. Key
22. Thrust Washer
23. Thrust Bearing
24. Grease Nipple
25. Bonnet
26. Seal Pack: Stem - Bonnet
27. Retaining Ring

P2 Product Family

Standard:

- P2E - Hammer-Union Bonnet; 10 000 PSI

Other Options:

- P2E BB - Bolted Bonnet; 6 000 PSI
- P2E 10k BB - Bolted Bonnet; 10 000 PSI
- P2E HT - Hammer Union; 6 000 PSI; High-Temperature Service
- C2E - Hammer Union; 6 000 PSI; Inline
- C2E BB - Bolted Bonnet; 6 000 PSI; Inline
- C2E HT - Hammer Union; 6 000 PSI; Inline; High-Temperature Service

chokes for all applications

recycle lines



manifold



vent valves



production



blow down

glycol injection

overboard dumps



subsea



level controllers

water injection

