

## The Point™ Two-Wire RF Series Point Level Switch



### One of the Drexelbrook RF Point Level Switches You Won't Have to Calibrate

Simply install ThePoint Series into the tank and apply power...that's it! Unlike other RF or capacitance systems that require calibration via setpoint potentiometers, jumpers, magnets, or pushbuttons, ThePoint Series reliably detects the absence or presence of material without any adjustments.

ThePoint Series software continuously monitors the application for changes in composition, dielectric or conductivity, and maintains a repeatable trip point on the probe. Other RF and capacitance systems require calibration adjustments when the process material is changed. Since ThePoint Series recognizes changes in material, it is ideal for non-dedicated tanks that are used for a wide variety of products.

### Intelligent Electronics Save Time and Money

- UNIQUE! - NO calibration or setpoint adjustments.
- UNIQUE! - Ignores changes in dielectric or conductivity.
- Automatically recognizes and ignores coatings to prevent false alarms.

### Diverse Applications

- Detects the absence or presence of liquids, slurries, and granulars.
- Capable of high pressures and temperatures.

### Economical Without Sacrifice

- Retains superior performance.
- Less maintenance than other technologies; no moving parts to hang up or wear out.

### Output

- 8mA (Alarm), 16mA (Normal)  
or
- 8mA (Normal), 16mA (Alarm)

### Lower Cost of Ownership

In addition to lower initial investment, ThePoint continues to save with little or no maintenance compared with other technologies. Further, the sensor can be lengthened or shortened in the field, saving need for additional purchases.

### Remote or Integral Electronics

Unlike many technologies, electronics can be remote mounted to a convenient or safe location



# Point Level Measurement

## The Point™

### Specifications

**Technology:**

RF Admittance

**Calibration:**

None

**Modes Of Operation:**

High and Low Level

**Repeatability:**

2 mm (0.08 inch) conductive liquids

**Response Time:**

Less than one second

**Ambient Electronic Temperature:**

-40 to 70°C (-40 to 158°F)

**Storage Temperature:**

-40 to 85°C (-40 to 185°F)

**Indicators:**

LEDs: Green Power, Red Alarm

**Time Delay:**

0-60 seconds, forward or reverse-acting

**Supply Voltage:**

13-30 VDC

**Power Consumption:**

2 watts maximum

**Output:**

8mA (Alarm), 16mA (Normal)

or

8mA (Normal), 16mA (Alarm)

**Housing:**

Powder-Coated aluminum with two cable entries.

**Cable Entry:**

M20 x 1.5 or 3/4-inch NPT

**Ingress Protection:**

IP66 NEMA 4X

**Approvals:****Integral**

Explosion Proof for Class I, Division 1, Groups B, C, and D; Dust Ignition Proof for Class II, III, Division 1, Groups E, F, and G; Non Incendiary for Class I, Division 2, Groups A, B, C, and D; Suitable for Class II, III, Division 2, Groups F and G hazardous (classified) locations Outdoor Type 4, 4X, IP66 with Intrinsically Safe connections to Class I, II, III, Division 1, Groups A, B, C, D, E, F, and G hazardous (classified) locations in accordance with control drawing 420-0004-220-CD

**Remote**

Explosion Proof for Class I, Division 1, Groups A, B, C, and D; Dust Ignition Proof for Class II, III, Division 1, Groups E, F, and G; Non Incendiary for Class I, Division 2, Groups A, B, C, and D; Suitable for Class II, III, Division 2, Groups F and G hazardous (classified) locations Outdoor Type 4, 4X, IP66 with Intrinsically Safe connections to Class I, II, III, Division 1, Groups A, B, C, D, E, F, and G hazardous (classified) locations in accordance with control drawing 420-0004-220-CD



II 1 GD Ex ia IIC  
T90°C  
T5...T2  
Tamb: -30°C to +70°C  
Install Per 420-0004-221-CD  
Ui = 30V  
Ii = 140mA  
Pi = 1w  
Ci = 0  
Li = 159uH



0344

**Test Safe**

Ex ia IIC T5 (Ta = -40° C to 70° C) IP66  
DIP A21 Ta 100  
ANZEx 05.3011X

### Wiring

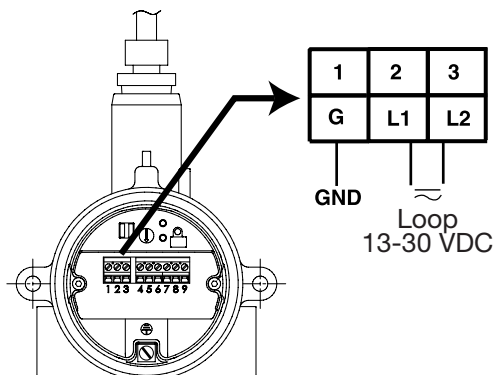

### Dimensions

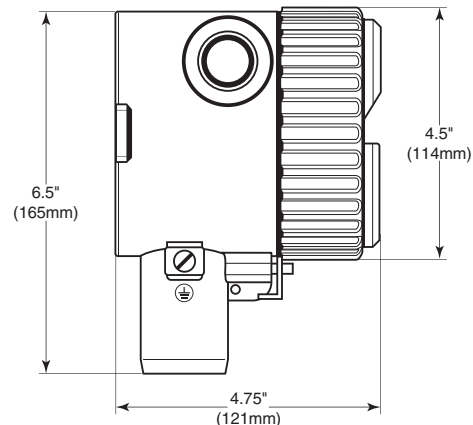

# Point Level Measurement

## The Point™

Model Numbering (continued on next page)

Technology			
P	RF Admittance		
Measurement Type			
N	Std Auto Cal		
L	Std 2 pF Fixed		
T	10 pF Auto Cal		
V	10 pF Fixed		
H	Hi Sense .5 pF Auto Cal		
P	Hi Sense .5 pF Fixed		
G	Hi Sense Manual		
M	Std Sense Manual		
Input			
T	Two Wire Power Supply 13 to 30 Vdc		
Output			
0	8-16 mA		
Housing			
0	No Approvals, NEMA 4X/IP66, M20 X 1.5 conduit entries		
1	No Approvals, NEMA 4X/IP66, ¾" NPT conduit entries		
2	ATEX / Testsafe Approved, NEMA 4X/IP66, M20 X 1.5 conduit entries		
3	FM / FMc / Testsafe approved, NEMA 4X/IP66, ¾" NPT conduit entries		
5	No Approvals, NEMA 4X/IP66, M20 conduit entries, Dual Seal, Perm-a-Seal sensors – only		
6	No approvals, NEMA 4X/IP66, ¾" NPT conduit entries, Dual Seal, Perm-a-Seal sensors – only		
7	FM / FMc Approved, NEMA 4X/IP66, ¾" NPT conduit entries, Dual Seal, Perm-a-Seal sensors – only		
9	No approvals, NEMA 4X/IP66, M20 conduit entries, Dual Seal, Non Perm-a-Seal sensors – only		
A	No Approvals, NEMA 4X/IP66, ¾" NPT conduit entries, Dual Seal, Non Perm-a-Seal sensors – only		
B	FM / FMc Approved, NEMA 4X/IP66, ¾" NPT conduit entries, Dual Seal, Non Perm-a-Seal sensors – only		
Electronics			
0	Integral		
1	Remote, no cable		
2	Rmt. w/ 3 m (10 ft.) G.P. cable		
3	Rmt. w/ 7.6 m (25 ft.) G.P. cable		
4	Rmt. w/ 10.6 m (35 ft.) G.P. cable		
5	Rmt. w/ 15.2 m (50 ft.) G.P. cable		
6	Rmt. w/ 23 m (75 ft.) G.P. cable		
7	Rmt. w/ (25 ft.) Tri-Ax Cable		
8	Rmt. w/ (50 ft.) Tri-Ax Cable		
9	Rmt. w/ (75 ft.) Tri-Ax Cable		
A	Rmt. w/ (10 ft.) Hi-Temp. Cable		
B	Rmt. w/ (25 ft.) 1st 10ft Hi-Temp. Cbl.		
C	Rmt. w/ (35 ft.) 1st 10ft Hi-Temp. Cbl.		
D	Rmt. w/ (50 ft.) 1st 10ft Hi-Temp. Cbl.		
E	Rmt. w/ (75 ft.) 1st 10ft Hi-Temp. Cbl.		
F	Rmt. w/ (5 ft.) G.P. Cable		
G	Rmt. w/ (5 ft.) Tri-Ax Cable		
H	Rmt. w/ (10 ft.) Tri-Ax Cable		
J	Rmt. w/ (35 ft.) Tri-Ax Cable		
K	Rmt. w/ (5 ft.) Hi-Temp. Cable		
Sensing Element			
Application	Sensing Element	Pressure/Temperature	Wetted Parts
00 General purpose	700-1202-001 remote 700-1202-021 integral	13.8 bar @ 232°C (200 PSI @ 450°F)	316SS and PEEK
01 Floating roof with cable attachment and brass bottom weight	700-1202-012 remote 700-1202-022 integral	13.8 bar @ 177°C (200 PSI @ 350°F)	316SS, Brass, and PEEK
02 General purpose, longer insertion lengths with cable attachment and 316SS bottom weight	700-1202-014 remote 700-1202-024 integral	13.8 bar @ 177°C (200 PSI @ 350°F)	316SS and PEEK
03 Proximity	700-1202-018 remote 700-1202-028 integral	13.8 bar @ 232°C (200 PSI @ 450°F)	316SS and PEEK with 76 mm (3) 316SS proximity plate
04 General purpose, high temperature and pressure	700-1202-041 remote 700-1202-042 integral	69 bar @ 121°C (1000 PSI @ 250°F) 20.7 bar @ 232°C (300 PSI @ 450°F)	316SS and PEEK
06 General purpose with FDA approved materials of construction	700-1202-031 remote 700-1202-032 integral	13.8 bar @ 232°C (200 PSI @ 450°F)	316SS and FDA grade PEEK
07 General purpose Granular materials	700-1202-010 remote 700-1202-020 integral	13.8 bar @ 232°C (200 PSI @ 450°F)	316SS and PEEK with 7/8 inch dia. 316SS collar
09 General purpose Granular materials with FDA approved materials of construction	700-1202-033 remote 700-1202-034 integral	13.8 bar @ 232°C (200 PSI @ 450°F)	316SS and FDA grade PEEK with 7/8 inch dia. 316SS collar
10 Corrosive liquids (2)(4)(9)	700-0001-018 remote	3.4 bar @ 149°C (50 PSI @ 300°F)	PFA
11 General purpose, higher pressure TFE compatibility required	700-0201-005 int/rem	69 bar @ 38°C (1000 PSI @ 100°F) 13.8 bar @ 232°C (200 PSI @ 450°F)	316SS and TFE
12 Corrosive material, higher pressure	700-0201-005 int/rem Hastelloy C	69 bar @ 38°C (1000 PSI @ 100°F) 13.8 bar @ 232°C (200 PSI @ 450°F)	Hastelloy C and TFE
13 Sanitary (3)	700-0201-036 int/rem	69 bar @ 38°C (1000 PSI @ 100°F) 13.8 bar @ 232°C (200 PSI @ 300°F)	316/316L SS and TFE
14 General Purpose, low pressure	700-0202-002 int/rem	3.4 bar @ 149°C (50 PSI @ 300°F) 1.4 bar @ 232°C (20 PSI @ 450°F)	316SS and TFE
15 Heavy duty, agitated tanks or material with high bulk density (1)	700-0202-043 remote	69 bar @ 38°C (1000 PSI @ 100°F) 13.8 bar @ 232°C (200 PSI @ 450°F)	316SS and TFE
16 High Integrity Seal for Hazardous Materials	700-0002-360 int/rem	34.5 bar @ 149°C (500 PSI @ 300°F)	PFA
17 Sanitary (3) lowpressure	700-0202-036 int/rem	3.4 bar @ 149°C (50 PSI @ 300°F)	316SS and TFE
18 Corrosive material, higher pressure with waterlike viscosity (4)	700-0001-022 int/rem	69 bar @ 38°C (1000 PSI @ 100°F) 34.5 bar @ 149°C (500 PSI @ 300°F)	TFE

**NOTE:** All Calibration modes are built into the standard unit. Modes can be changed in the field as required. (See Instruction Manual)

(Continued on Next Page)

# Point Level Measurement

## Model Numbering (continued from previous page)

	19	Interface Measurement	700-0002-023 int/rem	69 bar @ 38°C (1000 PSI @ 100°F) 34.5 bar @ 149°C (500 PSI @ 300°F)	316SS and TFE
	20	Miniature Pilot Plant Sensor (1)(7)	700-0209-002 remote	6.9 bar @ 121°C (100 PSI @ 250°F) 0 bar @ 232°C (0 PSI @ 450°F)	316 SS and TFE
	<b>Fly Ash Precipitators, Baghouse, and Economizers (1) (6)</b>				
		<b>Application</b>	<b>Sensing Element</b>	<b>Pressure/Temperature</b>	<b>Wetted Parts</b>
	31	No hopper Installation	700-0029-001 remote	0.1 bar @ 260°C (2 PSI @ 500°F)	316SS and TFE
	32	Hopper Installation up to 200mm (8 inches)	700-0029-002 remote	0.1 bar @ 260°C (2 PSI @ 500°F)	316SS and TFE
	33	Hopper Installation up to 406mm (16 inches)	700-0029-003 remote	0.1 bar @ 260°C (2 PSI @ 500°F)	316SS and TFE
	34	Hopper Installation up to 521mm (20.5 inches)	700-0029-004 remote	0.1 bar @ 260°C (2 PSI @ 500°F)	316SS and TFE
	35	Hopper Installation up to 635mm (25 inches)	700-0029-005 remote	0.1 bar @ 260°C (2 PSI @ 500°F)	316SS and TFE
	<b>Plugged Chute Detection (1) (5)</b>				
		<b>Application</b>	<b>Sensing Element</b>	<b>Pressure/Temperature</b>	<b>Wetted Parts</b>
	50	Flush Mount Sensor 305mm <sup>2</sup> (12 inches <sup>2</sup> ) heavy duty	700-0207-001 remote	0.1 bar @ 82°C (1 PSI @ 180°F)	304 SS and Polyurethane
	51	Flush Mount Sensor 305mm <sup>2</sup> (12 inches <sup>2</sup> ) higher temperature	700-0207-002 remote	0.1 bar @ 149°C (1 PSI @ 300°F)	304 SS and TFE
	52	Flush Mount Sensor 305mm <sup>2</sup> (12 inches <sup>2</sup> ) with curved radius 153, 229, 305 mm (6, 9, or 12 inches)	700-0207-003 remote	0.1 bar @ 82°C (1 PSI @ 180°F)	304 SS and Neoprene
	53	Flush Mount Sensor 305mm <sup>2</sup> (12 inches <sup>2</sup> ) extra heavy duty	700-0207-004 remote	0.1 bar @ 82°C (1 PSI @ 180°F)	410 SS and UHMW Polyethylene
	55	Flush Mount Sensor 203mm <sup>2</sup> (8 inches <sup>2</sup> ) heavy duty	700-0207-006 remote	0.1 bar @ 82°C (1 PSI @ 180°F)	304 SS and Polyurethane
	<b>High Pressure / High Temperature</b>				
	60	High Pressure & Temp.	700-0204-038 remote	137.9 bar @ 93°C (2000 PSI @ 200°F) 68.9 bar @ 260°C (1000 PSI @ 500°F)	316SS and Ceramic
	61	High Temperature	700-0204-002 remote	0 bar @ 816°C (0 PSI @ 1500°F)	316SS and Ceramic
	62	High Pressure & Temp.	700-0204-048 remote	275.8 bar @ 316°C (4000 PSI @ 600°F)	316SS
	<b>ZZ Sensing Element Not Listed</b>				

● **Mounting Type** (See separate Mounting Chart for first three digits)

	IL	CSL		IL	CSL
xxx1	457 mm (18")	152 mm (6")	xxxG	457 mm (18")	0 mm (0")
xxx2	305 mm (12")	152 mm (6")	xxxH	914 mm (36")	254 mm (10")
xxxA	152 mm (6")	51 mm (2")	xxxJ	914 mm (36")	0 mm (0")
xxxB	305 mm (12")	51 mm (2")	xxxK	1219 mm (48")	254 mm (10")
xxxC	305 mm (12")	89 mm (3.5")	xxxL	1524 mm (60")	254 mm (10")
xxxD	457 mm (18")	51 mm (2")	P00X	IL/CSL Other	
xxxE	457 mm (18")	89 mm (3.5")	A1BX	IL/CSL factory set for Fly Ash	
xxxF	457 mm (18")	254 mm (10")	xxxZ	Other	



Not all mounting options available with all sensing elements

**Notes:** CSL (Cote-Shield Length) should extend through Nozzle + Typical "Wall Buildup" + 2 Inches

- (1) Available with remote electronics only
- (2) Use A1P mounting option
- (3) Choose only sanitary mounting options
- (4) Available with 0-inch CSL only
- (5) Use P00X mounting option
- (6) Use A1B mounting option
- (7) Use A8B mounting option (¼-inch NPT)
- (8) Choose from flange mounting only
- (9) FM approved with remote electronics only

**NPT Threads**

<b>A1B</b>	¾"NPT	316SS
<b>A1C</b>	¾"NPT	Hastelloy C
<b>A1P</b>	¾"NPT	PFA

<b>A2B</b>	1"NPT	316SS
<b>A2C</b>	1"NPT	Hastelloy C

**Sanitary TriClamps**

<b>C2B</b>	1"TriClamp	316SS	<b>C4B</b>	2"TriClamp	316SS
<b>C3B</b>	1½"TriClamp	316SS			

**DIN Flanges**

<b>E01</b>	25 mm	16 bar	RF 316/316L SS	<b>E02</b>	25 mm	16 bar	RF CS
<b>EP1</b>	25 mm	40 bar	RF 316/316L SS	<b>EP2</b>	25 mm	40 bar	RF CS
<b>EQ1</b>	50 mm	16 bar	RF 316/316L SS	<b>EQ2</b>	50 mm	16 bar	RF CS
<b>ER1</b>	50 mm	40 bar	RF 316/316L SS	<b>ER2</b>	50 mm	40 bar	RF CS
<b>ES1</b>	80 mm	16 bar	RF 316/316L SS	<b>ES2</b>	80 mm	16 bar	RF CS
<b>ET1</b>	80 mm	40 bar	RF 316/316L SS	<b>ET2</b>	80 mm	40 bar	RF CS
<b>EU1</b>	100 mm	16 bar	RF 316/316L SS	<b>EU2</b>	100 mm	16 bar	RF CS
<b>EV1</b>	100 mm	40 bar	RF 316/316L SS	<b>EV2</b>	100 mm	40 bar	RF CS
<b>EW1</b>	150 mm	16 bar	RF 316/316L SS	<b>EW2</b>	150 mm	16 bar	RF CS
<b>EX1</b>	150 mm	40 bar	RF 316/316L SS	<b>EX2</b>	150 mm	40 bar	RF CS

**ANSI Flanges**

<b>DA1</b>	1"	150#	RF 316/316L SS	<b>DA2</b>	1"	150#	RF CS
<b>DB1</b>	1½"	150#	RF 316/316L SS	<b>DB2</b>	1½"	150#	RF CS
<b>DC1</b>	2"	150#	RF 316/316L SS	<b>DC2</b>	2"	150#	RF CS
<b>DD1</b>	2½"	150#	RF 316/316L SS	<b>DD2</b>	2½"	150#	RF CS
<b>DE1</b>	1"	300#	RF 316/316L SS	<b>DE2</b>	1"	300#	RF CS
<b>DF1</b>	1½"	300#	RF 316/316L SS	<b>DF2</b>	1½"	300#	RF CS
<b>DG1</b>	2"	300#	RF 316/316L SS	<b>DG2</b>	2"	300#	RF CS
<b>DH1</b>	2½"	300#	RF 316/316L SS	<b>DH2</b>	2½"	300#	RF CS
<b>DI1</b>	3"	150#	RF 316/316L SS	<b>DI2</b>	3"	150#	RF CS
<b>DJ1</b>	3"	300#	RF 316/316L SS	<b>DJ2</b>	3"	300#	RF CS
<b>DK1</b>	4"	150#	RF 316/316L SS	<b>DK2</b>	4"	150#	RF CS
<b>DL1</b>	4"	300#	RF 316/316L SS	<b>DL2</b>	4"	300#	RF CS
<b>DM1</b>	6"	150#	RF 316/316L SS	<b>DM2</b>	6"	150#	RF CS
<b>DN1</b>	6"	300#	RF 316/316L SS	<b>DN2</b>	6"	300#	RF CS



205 Keith Valley Road, Horsham, PA 19044 U.S.A.

Tel: 215-674-1234 Fax: 215 674-2731

Email: [drexelbrook.info@ametek.com](mailto:drexelbrook.info@ametek.com)

Web: [www.drexelbrook.com](http://www.drexelbrook.com)