



Flow-Tek AUTOMATOR
A Subsidiary of BRAY INTERNATIONAL, Inc.
PART NO. 92-1280-113A0-532
SERIAL NO. 130226
WARNING
BEFORE DISASSEMBLY COMPLETELY DISCONNECT AIR SUPPLY
AND RELEASE ALL PRESSURE WITHIN THE ACTUATOR. REFER
TO MAINTENANCE INSTRUCTIONS WITH SPECIAL EMPHASIS
ON SAFETY NOTES.
BLACK PIPER LINES, 4500 PSI (310 BAR) LIMITED. ENGINEERING BY BRAY 8801211
© 2004

Severe-Tek™ M4

NPS ½ - 4 | DN 15-100
ASME Limited Class 1700, 3100, 4500
Severe Service Metal Seated Ball Valves



Severe-Tek™ is Flow-Tek's High Performance Severe Service Metal Seated Ball Valve which is suitable for the harshest applications. Severe-Tek™ Series M4 valves are specifically designed and manufactured for power generation applications.

Each Series M4 valve has been designed to maximize the flow capacities and pressure class ratings to offer the smallest and most effective valve package. Flow-Tek offers the most competitive package by utilizing our own valve, actuation and accessories.

Flow-Tek's technical engineers are industry leaders with exclusive metal seated ball valve experience. Since the early 1980's, Flow-Tek has successfully found solutions and created performance

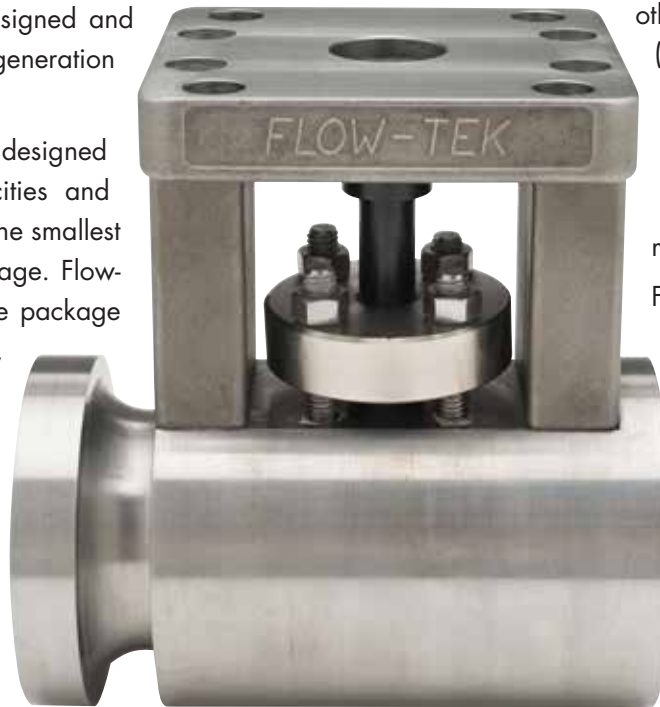

improvements for our customers. Our Severe-Tek™ valves have the very best improvements and features, such as upgraded trim, that will outperform other Metal Seated Ball Valves (MSBV) in the market. Flow-Tek is dedicated to continuous improvement and innovation in design and service to meet the customer's technical and commercial needs.

Flow-Tek's global sales, manufacturing and purchasing facilities allow us to produce the most technically advanced valves designed with the highest quality and workmanship at competitive pricing. Combined with our extensive service network, we are able to assist with any of your valve needs.

FLOW COEFFICIENTS

Pipe			Bore (inches) – C _v			Bore (mm) – K _v		
			C _v is the volume (in US gallons) of water at 60°F that will flow per minute through a valve with a pressure drop of one psi across the valve			K _v is the rate of flow of cold water in cubic metres per hour at a pressure drop of one kilogram per square centimeter across the valve		
NPS	DN	Schedule No.	0.63	1.03	1.56	16	26	40
½	15	STD/40	20	-	-	17.2	-	-
		XS/80	14	-	-	12.1	-	-
		160	-	-	-	-	-	-
		XXS	-	-	-	-	-	-
¾	20	STD/40	20	-	-	17.2	-	-
		XS/80	22	-	-	19.0	-	-
		160	19	-	-	16.4	-	-
		XXS	8	-	-	6.9	-	-
1	25	STD/40	17	71	-	14.7	61.2	-
		XS/80	18	63	-	15.5	54.3	-
		160	21	39	-	18.1	33.6	-
		XXS	18	18	-	15.5	15.5	-
1-½	40	STD/40	14	48	191	12.1	41.4	164.6
		XS/80	14	51	188	12.1	44.0	162.1
		160	15	58	143	12.9	50.0	123.3
		XXS	16	71	71	13.8	61.2	61.2
2	50	STD/40	-	41	135	-	35.3	116.4
		XS/80	-	42	148	-	36.2	127.6
		160	14	46	183	12.1	39.7	157.7
		XXS	14	51	189	12.1	44.0	162.9
2-½	65	STD/40	-	-	111	-	-	95.7
		XS/80	-	-	117	-	-	100.9
		160	-	-	130	-	-	112.1
		XXS	-	-	170	-	-	146.5
3	80	STD/40	-	-	96	-	-	82.8
		XS/80	-	-	99	-	-	85.3
		160	-	-	105	-	-	90.5
		XXS	-	-	119	-	-	102.6
4	100		Consult Factory			Consult Factory		

QUALITY, SAFETY, AND PERFORMANCE

As a result of our continual commitment to quality, our facilities have achieved ISO 9001:2008 for the design and manufacture of Severe-Tek™ valves.

We recognize that the safety performance of our product is critical to our customers, therefore, all major part components are traceable to reassure our customers of consistent reliability throughout its life cycle.

Our Severe-Tek™ products are certified to the requirements of Annex III, Module H of the PED 97/23/EC.

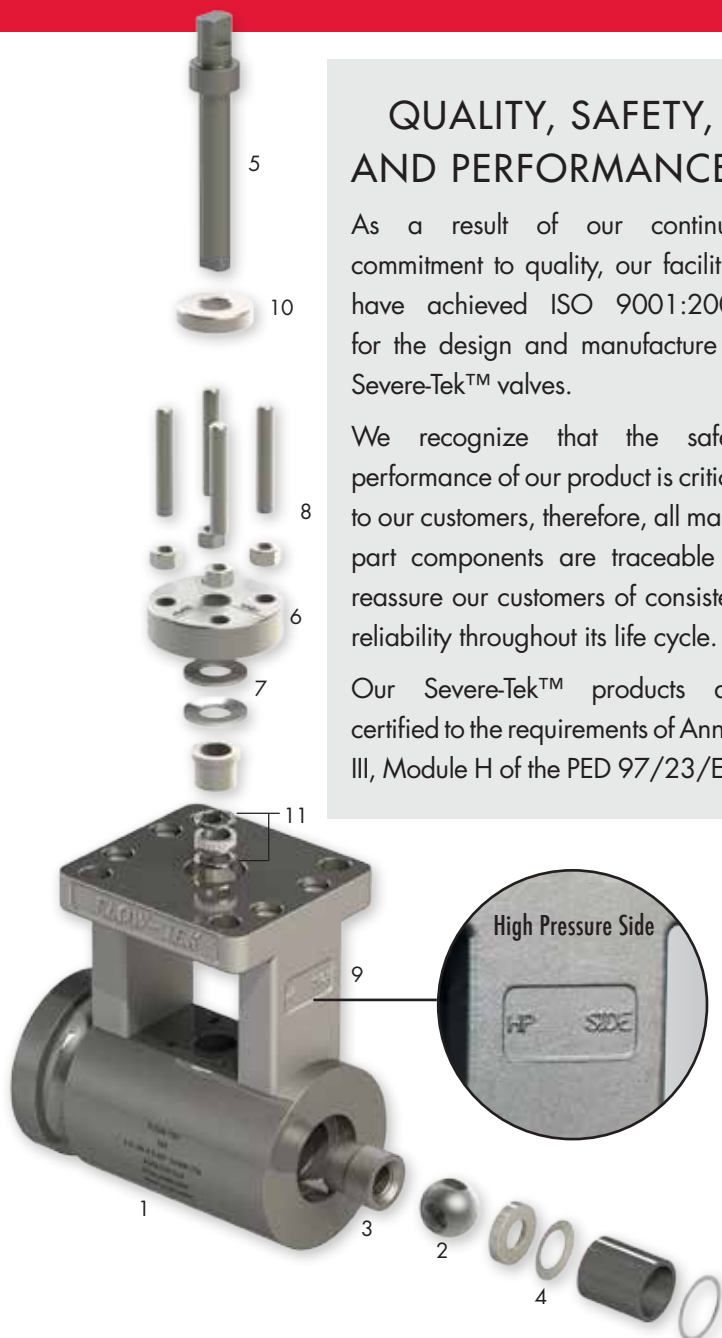

COMPONENTS & MATERIALS

ITEM / NAME	STAINLESS STEEL	QTY.
1. Body	A105, A182-F22 cl3, A182-F91	1
2. Ball	Inconel® 718 Fused Chromium Carbide	1
3. Seat	Inconel® 718 HVOF Chromium Carbide	1
4. Spring	Inconel® 718	1
5. Stem	431 Stainless Steel/Coated*	1
6. Gland	316 Stainless Steel	1
7. Live Loaded Spring	Inconel® 718 or X-750	2
8. Gland Bolting	A193 B8M	4
9. Bracket	A217 WCB	1
10. Upper Bearing Ring	416 Stainless Steel/Coated	1
11. Packing	Chesterton® Graphite Ring Set	1

*For 4500 Class & A182-F91 valves, stem material is Inconel® 718.



BALL VALVE VS GLOBE VALVE

A quarter turn ball valve operates smoothly. The globe valve's rising stem design causes continuous packing wear during operation.

Ball valve sealing is pressure assisted, while the globe valve design requires torque seating.

The straight flow path of the ball valve increases the C_v while protecting the sealing surfaces from the flow. The turbulent path and constant exposure of the globe valve's sealing surfaces severely shortens the life of the valve.

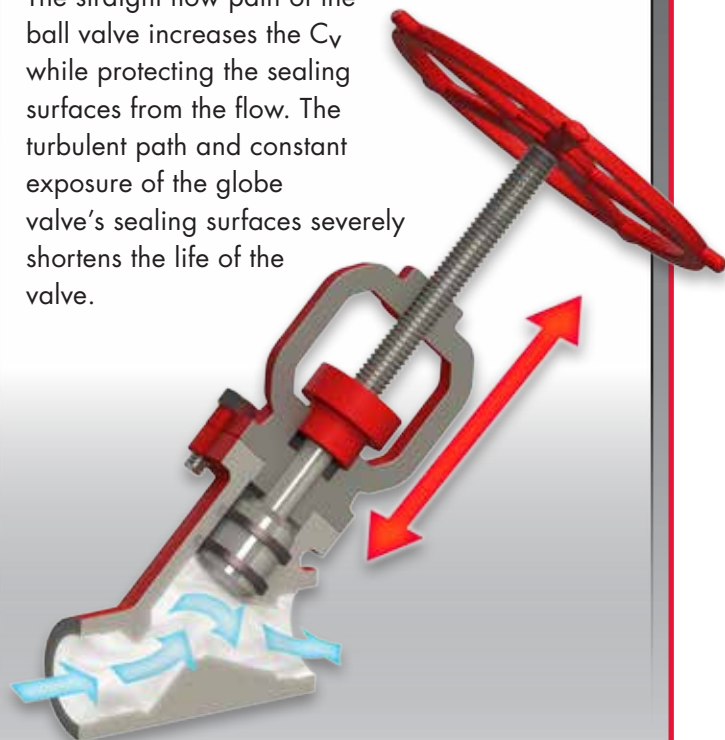

1. By utilizing the same material and coating composition for the ball and seat, both parts expand at the same rate during thermal cycling providing tight shutoff.
 - The entire ball and seat are seal-lapped together creating a true rounded ball-to-seat interface. This eliminates any irregularities found with traditional mate-lapping techniques.
 - Wider sealing surfaces reduce dynamic cycling stresses promoting extended valve life and tight shutoff.
2. Forged heavy walled unibody construction eliminates the body joint.
 - CNC machined for premium accuracy.
 - Transitioning angles maximize flow rates.
3. Cast steel bracket with increased thickness for superior rigidity.
 - CNC machined to fully align the body, bracket and stem eliminating side-to-side motion.
 - Permanently attached bracket.
4. Solid, high strength one piece stem engages the ball and extends to the top of the mounting flange for ease of automation.
 - Upper and lower bearings limit side-to-side motion of the stem.
 - Solid, high strength bearing ring prevents stem blow-out.
5. Large top mounting flange accepts ISO 5211 actuators.
6. Large Inconel® 718 Belleville spring exerts continuous force onto the ball and seat maintaining seal throughout operating temperatures.
7. Inconel® 718 springs live load the stem packing set.
8. External body groove reduces conductive heat from the post-weld heat treatment process.

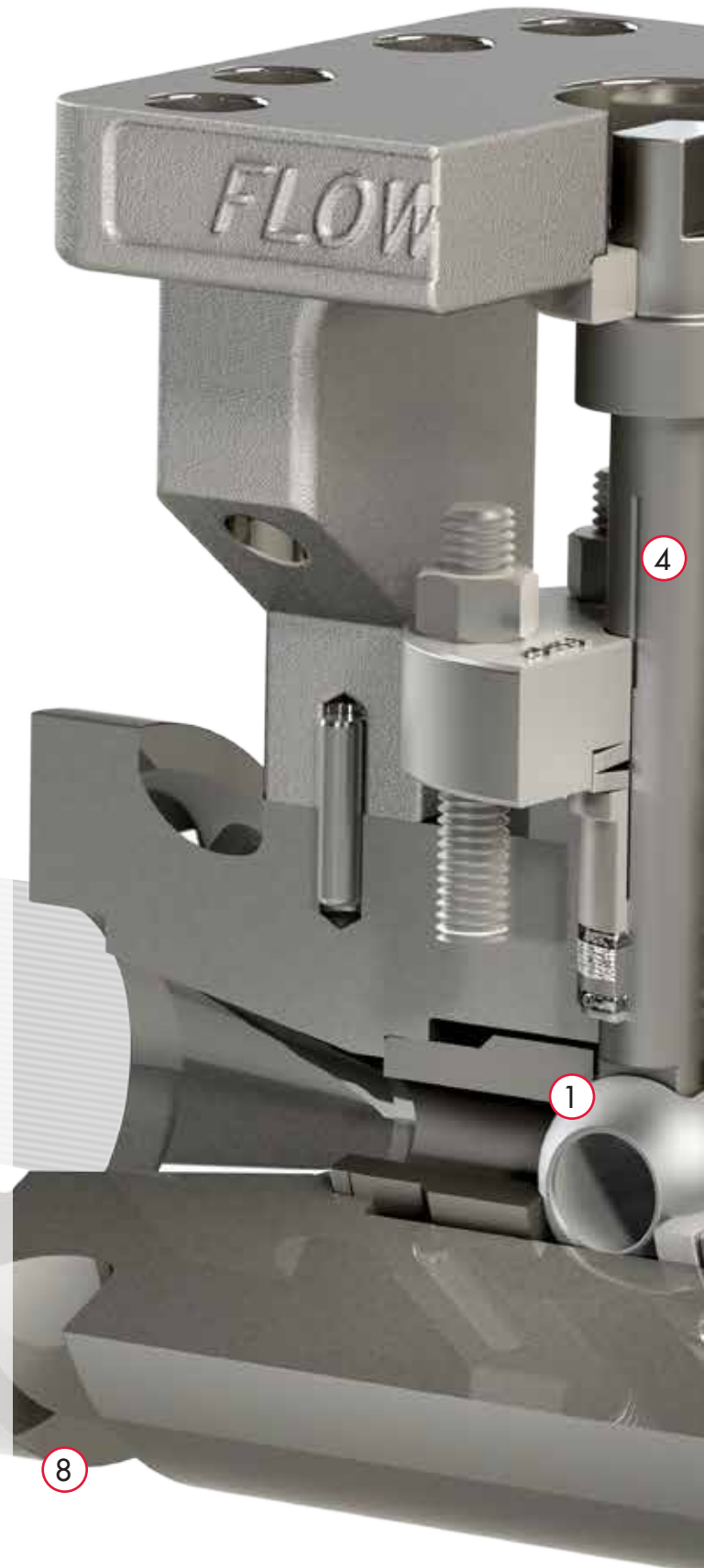

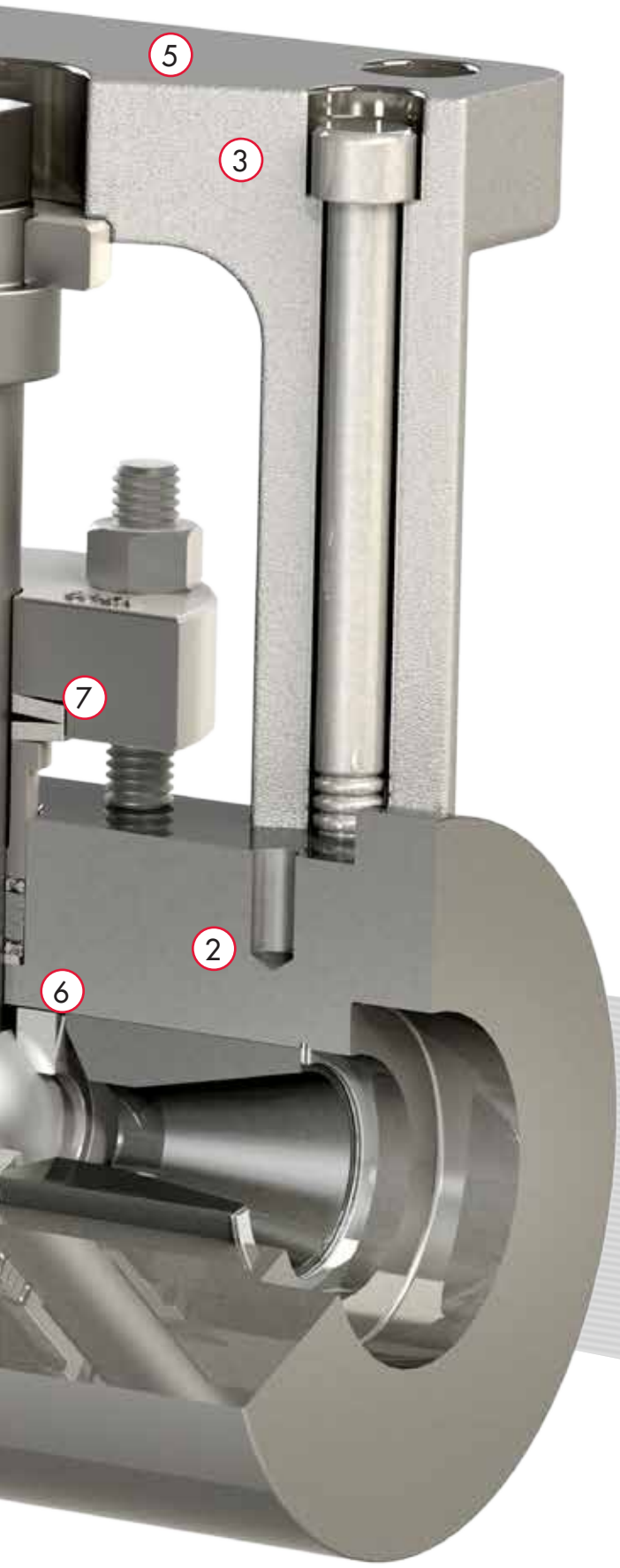

M4 - SPECIFICATIONS

Size Range*	NPS ½ - 2½ SW or BW DN 15 - 65
Bore Sizes*	0.63", 1.03", 1.56"
Body Materials*	A105 A182-F22 cl.3 A182-F91
Ball	Inconel® 718/Fused Chromium Carbide
Seat	Inconel® 718/HVOF Chromium Carbide
Pressure Ratings	1700, 3100, 4500, Limited Class
Temperature	up to 1100°F (593°C)
End Connections	SW per ASME B16.11 BW per ASME B16.25
Test Standards	API 598, MSS SP-61
Characteristics	On-Off, Zero Leakage

*Other sizes and materials available on request.

SPECIAL FEATURES:

- VALVE MARKINGS CONFORM TO API 607
- DIRECT MOUNTING OF ACTUATOR
- UPGRADED BALL & SEAT MATERIALS
- LARGE BORES, MORE FLOW CAPACITY

VALVE DIMENSIONS

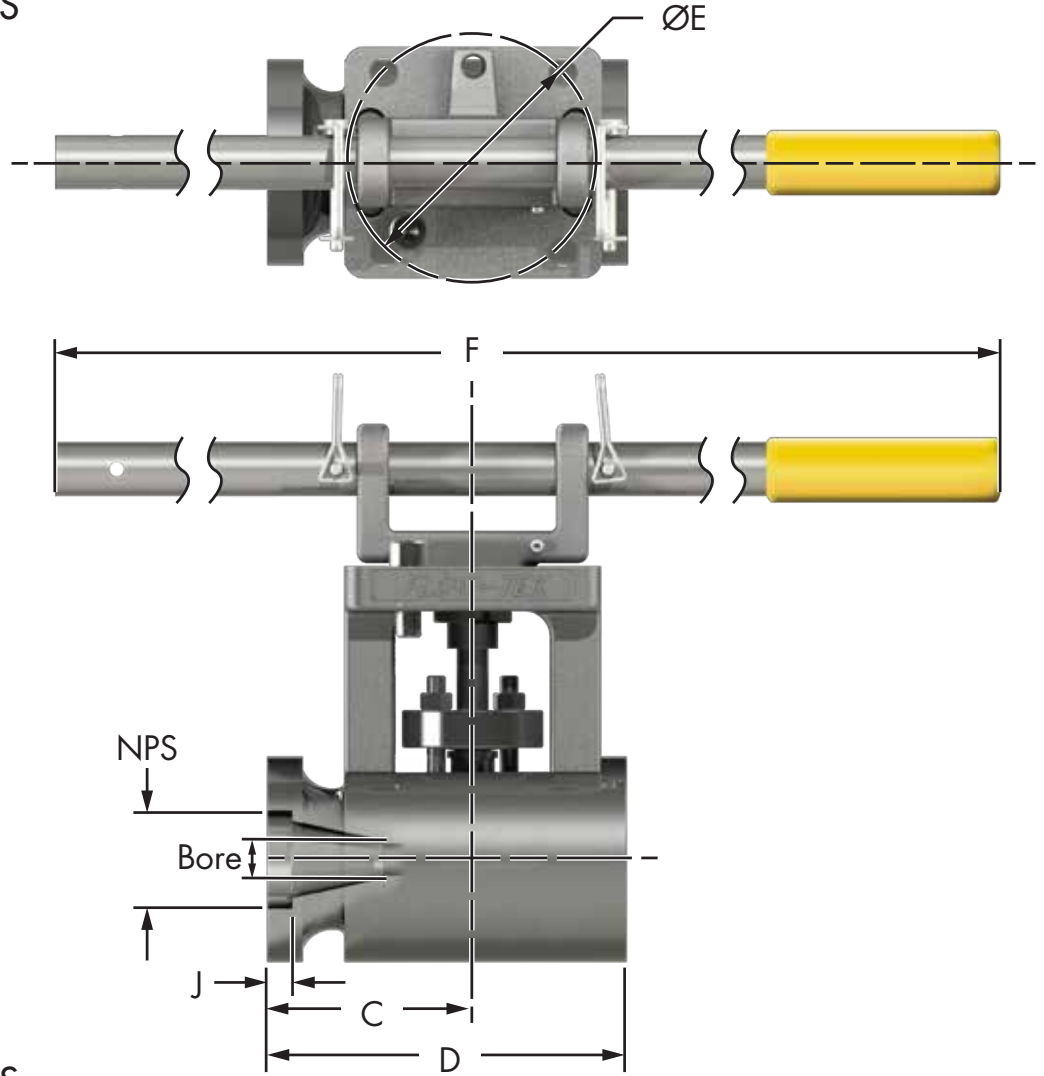

VALVE DIMENSIONS

BORE	Pipe Size*		J (Socket Depth)		Up to ASME 3100		ASME 4500		Up to ASME 3100			ASME 4500		E ISO 5211	F		G		Weight						
	NPS	DN	in.	mm	in.	mm	in.	mm	in.	mm	in.	mm	in.		mm	in.	mm	in.	mm	lbs.	Kg				
0.63" (16.0mm)	1/2	15	0.38	10	4.00	102	4.00	102	5.69	145	4.00	102	8.00	203	4.00	102	8.00	203	F12	28.00	711	8.45	215	39	18
	3/4	20	0.50	13	4.00	102	4.00	102	5.69	145	4.00	102	8.37	213	4.00	102	8.37	213	F12	28.00	711	8.45	215	39	18
	1	25	0.50	13	4.00	102	4.00	102	5.75	146	4.00	102	7.00	178	4.00	102	7.00	178	F12	28.00	711	8.45	215	38	17
	1 1/2	40	0.50	13	4.00	102	4.00	102	5.75	146	4.00	102	7.00	178	4.25	108	7.63	194	F12	28.00	711	8.45	215	39	18
	2	50	0.62	16	4.50	114	4.50	114	5.69	145	4.65	118	8.50	216	4.65	118	8.50	216	F12	28.00	711	8.45	215	48	22
1.03" (26.0mm)	3/4	20	0.50	13	4.75	121	4.75	121	6.45	164	5.54	141	10.34	263	5.54	141	10.34	263	F12/F16	36.00	914	9.51	242	63	29
	1	25	0.50	13	4.75	121	4.75	121	6.45	164	4.50	114	9.58	243	4.50	148	9.58	243	F12/F16	36.00	914	9.51	242	63	29
	1 1/2	40	0.50	13	4.75	121	4.75	121	6.45	164	4.50	114	8.25	210	4.50	114	8.25	210	F12/F16	36.00	914	9.51	242	60	27
	2	50	0.62	16	4.75	121	5.50	140	6.45	164	4.50	114	8.25	210	5.13	130	9.75	248	F12/F16	36.00	914	9.51	242	81	37
	2 1/2	65	0.62	16	5.50	140	5.50	140	6.45	164	5.13	130	9.75	248	5.25	133	9.88	251	F12/F16	36.00	914	9.51	242	81	37
1.56" (40.0mm)	1 1/2	40	0.50	13	5.75	146	not applicable	not applicable	8.33	212	6.54	166	11.81	300	not applicable	not applicable	not applicable	not applicable	F16	not applicable	not applicable	85	39		
	2	50	0.62	16	5.75	146			8.33	212	5.12	130	10.77	274					F16			84	38		
	2 1/2	65	0.62	16	5.75	146			8.33	212	5.13	130	9.00	229					F16			78	35		

*Values are for socket weld valves, for 3" and 4" or other valve types consult the factory. Information subject to change; for most recent updates, please visit our website www.flow-tek.com

PRESSURE/TEMPERATURE RATINGS °F ASME B16.34 LIMITED CLASS 2013 EDITION

MATERIAL CLASS	A105						A182 F22 cl.3						A182 F91					
	900	1500	1700	2500	3100	4500	900	1500	1700	2500	3100	4500	900	1500	1700	2500	3100	4500
-20° to 100°	2,250	3,750	4,250	6,250	7,750	11,250	2,250	3,750	4,250	6,250	7,750	11,250	2,250	3,750	4,250	6,250	7,750	11,250
200°	2,250	3,750	4,250	6,250	7,750	11,250	2,250	3,750	4,250	6,250	7,750	11,250	2,250	3,750	4,250	6,250	7,750	11,250
300°	2,250	3,700	4,194	6,170	7,651	11,105	2,220	3,695	4,188	6,160	7,639	11,090	2,250	3,750	4,250	6,250	7,750	11,250
400°	2,200	3,665	4,153	6,105	7,572	10,995	2,185	3,640	4,125	6,065	7,520	10,915	2,250	3,750	4,250	6,250	7,750	11,250
500°	2,200	3,665	4,153	6,105	7,572	10,995	2,175	3,620	4,103	6,035	7,484	10,865	2,250	3,750	4,250	6,250	7,750	11,250
600°	2,200	3,665	4,153	6,105	7,572	10,995	2,165	3,605	4,086	6,010	7,452	10,815	2,250	3,750	4,250	6,250	7,750	11,250
650°	2,145	3,575	4,052	5,960	7,391	10,730	2,145	3,580	4,057	5,965	7,396	10,735	2,250	3,750	4,250	6,250	7,750	11,250
700°	2,075	3,455	3,916	5,760	7,142	10,365	2,120	3,535	4,007	5,895	7,308	10,605	2,200	3,665	4,154	6,110	7,576	10,995
750°	1,905	3,170	3,593	5,285	6,554	9,515	2,120	3,535	4,007	5,895	7,308	10,605	2,185	3,645	4,130	6,070	7,528	10,930
800°	1,545	2,570	2,913	4,285	5,314	7,715	2,120	3,535	4,007	5,895	7,308	10,605	2,160	3,600	4,080	6,000	7,440	10,800
850°	1,195	1,995	2,260	3,320	4,118	5,980	2,030	3,385	3,837	5,645	7,000	10,160	2,030	3,385	3,837	5,645	7,000	10,160
900°	Permissible but not recommended for prolonged use above 800°F						1,800	3,000	3,400	5,000	6,200	9,000	1,800	3,000	3,400	5,000	6,200	9,000
950°							1,415	2,360	2,624	3,930	4,872	7,070	1,415	2,360	2,674	3,930	4,872	7,070
1000°							1,045	1,785	2,042	3,119	3,983	6,213	1,260	2,105	2,385	3,505	4,347	6,310
1050°							681	1,170	1,337	2,038	2,604	4,064	1,260	2,105	2,385	3,505	4,347	6,310
1100°							426	732	838	1,282	1,635	2,546	1,175	2,015	2,284	3,360	4,166	6,045

PRESSURE/TEMPERATURE RATINGS °C ASME B16.34 LIMITED CLASS 2013 EDITION

MATERIAL CLASS	A105						A182 F22 cl.3						A182 F91					
	900	1500	1700	2500	3100	4500	900	1500	1700	2500	3100	4500	900	1500	1700	2500	3100	4500
-29° to 38°	155.1	258.6	293.1	430.9	534.3	775.7	155.1	258.6	293.1	430.9	534.3	775.7	155.1	258.6	293.1	430.9	534.3	775.7
50°	155.1	258.6	293.1	430.9	534.3	775.7	155.1	258.6	293.1	430.9	534.3	775.7	155.1	258.6	293.1	430.9	534.3	775.7
100°	154.9	258.2	292.6	430.3	533.6	774.5	154.9	258.1	292.5	430.2	533.4	774.3	155.1	258.6	293.1	430.9	534.3	775.7
150°	153.1	255.2	289.2	425.3	527.4	765.5	152.9	254.8	288.8	424.6	526.5	764.3	155.1	258.6	293.1	430.9	534.3	775.7
200°	151.7	252.9	286.6	421.4	522.6	758.6	150.7	251.1	284.6	418.5	519.0	753.4	155.1	258.6	293.1	430.9	534.3	775.7
250°	151.6	252.6	286.3	421.1	522.1	757.9	149.9	249.9	283.2	416.5	516.5	749.7	155.1	258.6	293.1	430.9	534.3	775.7
300°	151.6	252.6	286.3	421.1	522.1	757.9	149.3	248.9	282.1	414.8	514.4	746.7	155.1	258.6	293.1	430.9	534.3	775.7
325°	150.3	250.6	284.0	417.6	517.8	751.7	148.8	248.0	281.1	413.3	512.5	743.9	155.1	258.6	293.1	430.9	534.3	775.7
350°	146.7	244.6	277.2	407.6	505.4	733.7	147.6	246.0	278.8	410.0	508.4	738.1	154.3	257.1	291.4	428.6	531.4	771.4
375°	141.3	235.5	266.9	392.5	486.7	706.5	146.3	243.8	276.3	406.3	503.8	731.3	151.5	252.5	286.2	420.9	521.9	757.4
400°	130.2	217.0	245.9	361.7	448.5	651.0	146.3	243.8	276.3	406.3	503.8	731.3	150.6	251.2	284.6	418.3	518.8	753.2
425°	107.9	179.8	203.8	299.6	371.5	539.3	146.3	243.8	276.3	406.3	503.8	731.3	148.9	248.2	281.3	413.7	513.0	744.6
450	Permissible but not recommended for prolonged use above 425°C						141.4	235.8	267.3	393.1	487.5	707.6	141.4	235.8	267.3	393.1	487.5	707.6
475°							128.2	213.7	242.2	356.3	441.8	641.3	128.2	213.7	242.2	356.3	441.8	641.3
500°							107.1	178.6	202.4	297.5	368.9	535.4	107.1	178.6	202.4	297.5	368.9	535.4
538°							71.9	123.1	140.8	215.2	274.7	428.3	90.4	155.1	177.3	270.7	345.6	535.4
550°							61.0	104.4	119.4	182.3	232.8	363.1	86.9	145.1	164.4	241.7	299.7	435.1
575°							41.1	70.3	80.4	122.9	156.8	244.6	86.9	145.1	164.4	241.7	299.7	435.1
600°							26.8	46.0	52.6	80.3	102.5	159.9	76.0	130.3	149.0	227.5	290.4	428.8

BRAY INTERNATIONAL, INC

USA

Houston, TX. +281.894.5454

FLOW-TEK

USA

Houston, TX +832.912.2300

CHINA

Hangzhou, Zhejiang +86.571.828.52200

BRAZIL

Paulinia SP-Brazil +55.19.3517.5555

BRAY CONTROLS / FLOW-TEK

BRAY CONTROLS USA

Houston, TX +832.912.2300

ARGENTINA

Buenos Aires + 54.11.4362.0666

BENELUX

Heerhugowaard +31.72.572.1410

BRAZIL

Paulinia SP-Brazil +55.19.3517.6161

CANADA

Montréal +514.344.2729

CHILE

Santiago +56.2739.2966

CHINA

Hangzhou, Zhejiang +86.571.828.52200

GERMANY

Krefeld +49.2151.53360

INDIA

Gujarat +91.2667.664444

MEXICO

Zapopan, Jalisco, +52.33.3836.4460

PACIFIC

Melbourne, Australia +613.9580.9755

PERU

Lima +511.251.0251

POLAND

Oświęcim +48.33.842.1968

UNITED KINGDOM

Inchinnan +44.141.812.5199

VIETNAM

Ho Chi Minh City +84.8.3742.3428

RITEPRO

CANADA,

Montréal +514.324.8900

CHINA,

Hangzhou, Zhejiang +86.571.828.52200

All statements, technical information, and recommendations in this bulletin are for general use only. Consult Flow-Tek representatives or factory for the specific requirements and material selection for your intended application. The right to change or modify product design or product without prior notice is reserved.

Flow-Tek® is a registered trademark of Flow-Tek, Inc.
© 2014 Flow-Tek, Inc. All rights reserved.

F-2806_EL_SevereService_06_05_2015



▲ **FLOW-TEK - USA - Office & Manufacturing**

**Global manufacturing,
service around the corner**

To serve you locally, each region maintains a
factory certified sales and service network
for all Bray International products.



▼ **WORLD HEADQUARTERS - BRAY INTERNATIONAL, INC. - USA**



Flow-Tek®

A Subsidiary of BRAY INTERNATIONAL, Inc.
8323 N. Eldridge Pkwy #100 Houston, Texas 77041
832.912.2300 Fax: 832.912.2301 www.flow-tek.com
severe.tekquotes@flow-tek.com