

## IntelliPoint RF™ Series

### Two-Wire Point Level Switch

### One of the Drexelbrook RF Point Level Switches You Won't Have to Calibrate



The only RF switch you won't calibrate. Simply install the IntelliPoint RF Series into the tank and apply power...that's it! Unlike other RF or capacitance systems that require calibration via setpoint potentiometers, jumpers, magnets, or pushbuttons, the IntelliPoint RF Series reliably detects the absence or presence of material without any adjustments.

The IntelliPoint RF Series software continuously monitors the application for changes in composition, dielectric or conductivity, and maintains a repeatable trip point on the probe. Other RF and capacitance systems require calibration adjustments when the process material is changed. Since the IntelliPoint RF Series recognizes changes in material, it is ideal for non-dedicated tanks that are used for a wide variety of products.

#### Intelligent Electronics

- No calibration or setpoint adjustments.
- Ignores changes in dielectric or conductivity.
- Automatically recognizes and ignores coatings to prevent false alarms.
- Continuous self-test monitors circuits and sensing elements for faults.

#### Diverse Applications

- Detects the absence or presence of liquids, slurries, interfaces and granulars.

#### Output

- 8mA (Alarm) 16mA (Normal) or 8mA (Normal) and 16 mA (Alarm)

#### Remote or Integral Electronics

- Unlike many technologies, electronics can be remote mounted to a convenient or safe location

#### Self-Test Feature

Automatic and manual test functions ensure proper system operation. An AutoVerify™ self-check circuit continuously monitors that the complete system is functioning properly. The Manual Certify not only checks the function of the system, but also checks the AutoVerify self-test circuits to make sure that they are also working properly.

#### Dual Compartment Housing

New dual compartment housing separates the customer wiring from the sensing element and operating circuits. The encapsulated power supply/terminal block design eliminates the possibility of damage caused by moisture in the conduit.



# Point Level Measurement

## IntelliPoint RF™ Series

### Specifications

**Technology:**  
RF Admittance

**Calibration:**  
None

**Modes Of Operation:**  
High and Low Level

**Repeatability:**  
2 mm (0.08 inch) conductive liquids

**Response Time:**  
Less than one second

**Ambient Electronic Temperature:**  
-30 to 70°C (-22 to 158°F)

**Storage Temperature:**  
-40 to 85°C (-40 to 185°F)

**Indicators:**  
LEDs: Green Power, Red Alarm

**Self-Check:**  
AutoVerify automatically and continuously checks electronics and sensing element for faults. Manual Certify checks that the AutoVerify circuits are functioning.

**Time Delay:**  
0-60 seconds, forward or reverse-acting

**Supply Voltage:**  
13-30 Vdc

**Power Consumption:**  
2 watts maximum

**Output:**

8 mA - Alarm	8 mA - Normal
16 mA - Normal	16 mA - Alarm
22 mA - Fault	5 mA - Fault

**Housing:**  
Dual Compartment, Powder-Coated aluminum with two cable entries

**Cable Entry:**  
M20 x 1.5 ATEX  
¾-inch NPT FM/FMc

**Ingress Protection:**  
IP66 NEMA 4X

### Approvals:



FM approved. Explosion-proof for use in Class I, Division 1, Groups A, B, C, & D; Dust-Ignition proof for Class II, III, Division 1, Groups E, F, & G; Non-incendiary for use in Class I, Division 2, Groups A, B, C & D; Suitable for Class II, III, Division 2, Groups F & G Hazardous (Classified) Indoor and Outdoor Type 4, 4X, IP66 locations with Intrinsically Safe connections to Class I, II, III, Division 1, Groups A, B, C, D, E, F, and G hazardous (Classified) locations in accordance with entity requirements and control drawing 420-0004-173-CD.



II 1 G Ex ia IIC T5... T2 -30°C ≤ TAMB ≤ +70°C; IP66  
II 1 D Ex ia IIIC T90°C -30°C ≤ TAMB ≤ +70°C; IP66



0575

**MTTF (Mean Time to Failure):**  
110 Years, Independently Tested

### Wiring

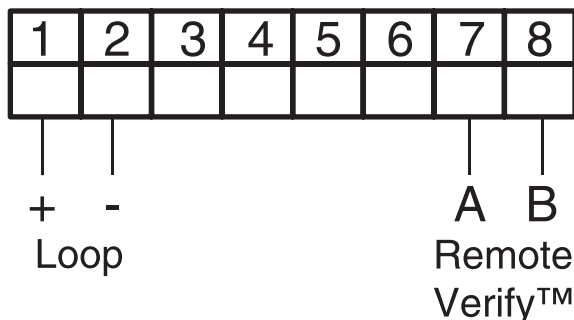

### Dimensions

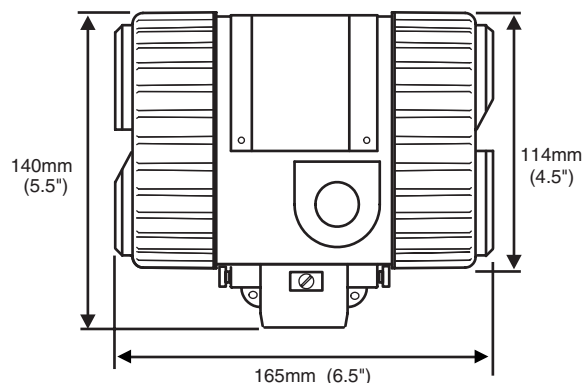

# Point Level Measurement

## IntelliPoint RF™ Series

### Model Numbering (continued on next page)

<b>Technology</b>					
R	RF Admittance				
<b>Measurement Type</b>					
N	No Calibration (Standard)	T	10pf Auto Calibration		
M	Manual Setpoint Adjustment	V	10pf Fixed		
H	High Sensitivity	H	High Sensitivity .5 pf Fixed		
G	High Sensitivity Manual Setpoint Adjustment	R	High Sensitivity		
L	Standard Auto Calibration				
<b>Input</b>					
T	Two wire Power Supply, 13-30 Vdc				
<b>Housing</b>					
0	No Approvals, NEMA 4X/IP66, M20 X 1.5 conduit entries				
1	No Approvals, NEMA 4X/IP66, ¾" NPT conduit entries				
2	ATEX Approved, NEMA 4X/IP66, M20 X 1.5 conduit entries				
3	FM / FMc Approved, NEMA 4X/IP66, ¾" NPT conduit entries				
5	No Approvals, NEMA 4X/IP66, M20 X 1.5 conduit entries, Dual Seal, Perm-a-Seal sensors – only				
6	No Approvals, NEMA 4X/IP66, ¾" NPT conduit entries, Dual Seal, Perm-a-Seal sensors – only				
7	FM / FMc Approved, NEMA 4X/IP66, ¾" NPT conduit entries, Dual Seal, Perm-a-Seal sensors – only				
9	No Approvals, NEMA 4X/IP66, M20 X 1.5 conduit entries, Dual Seal, Non Perm-a-Seal sensors – only				
A	No Approvals, NEMA 4X/IP66, ¾" NPT conduit entries, Dual Seal, Non Perm-a-Seal sensors – only				
B	FM / FMc Approved, NEMA 4X/IP66, ¾" NPT conduit entries, Dual Seal, Non Perm-a-Seal sensors – only				
<b>Electronics</b>					
0	Integral	7	Rmt. w/ (25 ft.) Tri-Ax Cable	E	Rmt. w/ (75 ft.) 1st 10ft Hi-Temp. Cbl.
1	Remote, no cable	8	Rmt. w/ (50 ft.) Tri-Ax Cable	F	Rmt. w/ (5 ft.) G.P. Cable
2	Rmt. w/ 3 m (10 ft.) G.P. Cable	9	Rmt. w/ (75 ft.) Tri-Ax Cable	G	Rmt. w/ (5 ft.) Tri-Ax Cable
3	Rmt. w/ 7.6 m (25 ft.) G.P. Cable	A	Rmt. w/ (10 ft.) Hi-Temp. Cable	H	Rmt. w/ (10 ft.) Tri-Ax Cable
4	Rmt. w/ 10.6 m (35 ft.) G.P. Cable	B	Rmt. w/ (25 ft.) 1st 10ft Hi-Temp. Cbl.	J	Rmt. w/ (35 ft.) Tri-Ax Cable
5	Rmt. w/ 15.2 m (50 ft.) G.P. Cable	C	Rmt. w/ (35 ft.) 1st 10ft Hi-Temp. Cbl.	K	Rmt. w/ (5 ft.) Hi-Temp. Cable
6	Rmt. w/ 23 m (75 ft.) G.P. Cable	D	Rmt. w/ (50 ft.) 1st 10ft Hi-Temp. Cbl.		
<b>Output</b>					
0	8-16 mA Output				
<b>Sensing Element</b>					
	<b>Application</b>	<b>Sensing Element</b>	<b>Pressure/Temperature</b>	<b>Wetted Parts</b>	
00	General purpose	700-1202-001 remote 700-1202-021 integral	13.8 bar @ 232°C (200 PSI @ 450°F)	316SS and PEEK	
01	Floating roof with cable attachment and brass bottom weight	700-1202-012 remote 700-1202-022 integral	13.8 bar @ 232°C (200 PSI @ 350°F)	316SS, Brass, and PEEK	
02	General purpose, longer insertion lengths with cable attachment and 316SS bottom weight	700-1202-014 remote 700-1202-024 integral	13.8 bar @ 232°C (200 PSI @ 350°F)	316SS and PEEK	
03	Proximity	700-1202-018 remote 700-1202-028 integral	13.8 bar @ 232°C (200 PSI @ 450°F)	316SS and PEEK with 76 mm (3) 316SS proximity plate	
04	General purpose, high temperature and pressure	700-1202-041 remote 700-1202-042 integral	69 bar @ 121°C (1000 PSI @ 250°F) 20.7 bar @ 232°C (300 PSI @ 450°F)	316SS and PEEK	
06	General purpose with FDA approved materials of construction	700-1202-031 remote 700-1202-032 integral	13.8 bar @ 232°C (200 PSI @ 450°F)	316SS and FDA grade PEEK	
07	General purpose Granular materials	700-1202-010 remote 700-1202-020 integral	13.8 bar @ 232°C (200 PSI @ 450°F)	316SS and PEEK with 7/8 inch dia. 316SS collar	
09	General purpose Granular materials with FDA approved materials of construction	700-1202-033 remote 700-1202-034 integral	13.8 bar @ 232°C (200 PSI @ 450°F)	316SS and FDA grade PEEK with 7/8 inch dia. 316SS collar	
10	Corrosive liquids (2)(4)(9)	700-0001-018 remote	3.4 bar @ 149°C (50 PSI @ 300°F)	PFA	
11	General purpose, higher pressure TFE compatibility required	700-0201-005 int/rem	69 bar @ 38°C (1000 PSI @ 100°F) 34.5 bar @ 149°C (500psi @ 300°F)	316SS and TFE	
12	Corrosive material, higher pressure	700-0201-005 int/rem Hastelloy C	69 bar @ 38°C (1000 PSI @ 100°F) 34.5 bar @ 149°C (500psi @ 300°F)	Hastelloy C and TFE	
14	General Purpose, low pressure	700-0202-002 int/rem	3.4 bar @ 149°C (50 PSI @ 300°F) 1.4 bar @ 232°C (20 PSI @ 450°F)	316SS and TFE	
15	Heavy duty, agitated tanks or material with high bulk density (1)	700-0202-043 remote	69 bar @ 38°C (1000 PSI @ 100°F) 34.5 bar @ 149°C (500psi @ 300°F)	316SS and TFE	
16	High Integrity Seal for Hazardous Materials	700-0002-360 int/rem	34.5 bar @ 149°C (500 PSI @ 300°F)	PFA	
18	Corrosive material, higher pressure with waterlike viscosity (4)	700-0001-022 int/rem	69 bar @ 38°C (1000 PSI @ 100°F) 34.5 bar @ 149°C (500 PSI @ 300°F)	TFE	
19	Interface Measurement	700-0002-023 int/rem	69 bar @ 38°C (1000 PSI @ 100°F) 34.5 bar @ 149°C (500 PSI @ 300°F)	316SS and TFE	
20	Miniature Pilot Plant Sensor (1)(7)	700-0209-002 remote	6.9 bar @ 121°C (100 PSI @ 250°F) 0 bar @ 232°C (0 PSI @ 450°F)	316 SS and TFE	

(Continued on next page)

# Point Level Measurement

## IntelliPoint RF™ Series

Model Numbering (continued from previous page)

Fly Ash Precipitators, Baghouse, and Economizers (1) (6)			
Application	Sensing Element	Pressure/Temperature	Wetted Parts
31 No hopper Installation	700-0029-001 remote	0.1 bar @ 260°C (2 PSI @ 500°F)	316SS and TFE
32 Hopper Installation up to 200mm (8 inches)	700-0029-002 remote	0.1 bar @ 260°C (2 PSI @ 500°F)	316SS and TFE
33 Hopper Installation up to 406mm (16 inches)	700-0029-003 remote	0.1 bar @ 260°C (2 PSI @ 500°F)	316SS and TFE
34 Hopper Installation up to 521mm (20.5 inches)	700-0029-004 remote	0.1 bar @ 260°C (2 PSI @ 500°F)	316SS and TFE
35 Hopper Installation up to 635mm (25 inches)	700-0029-005 remote	0.1 bar @ 260°C (2 PSI @ 500°F)	316SS and TFE
Plugged Chute Detection (1) (5)			
Application	Sensing Element	Pressure/Temperature	Wetted Parts
50 Flush Mount Sensor 305mm <sup>2</sup> (12 inches <sup>2</sup> ) heavy duty	700-0207-001 remote	0.1 bar @ 82°C (1 PSI @ 180°F)	304 SS and Polyurethane
51 Flush Mount Sensor 305mm <sup>2</sup> (12 inches <sup>2</sup> ) higher temperature	700-0207-002 remote	0.1 bar @ 149°C (1 PSI @ 300°F)	304 SS and TFE
52 Flush Mount Sensor 305mm <sup>2</sup> (12 inches <sup>2</sup> ) with curved radius 153, 229, 305 mm (6, 9, or 12 inches)	700-0207-003 remote	0.1 bar @ 82°C (1 PSI @ 180°F)	304 SS and Neoprene
53 Flush Mount Sensor 305mm <sup>2</sup> (12 inches <sup>2</sup> ) extra heavy duty	700-0207-004 remote	0.1 bar @ 82°C (1 PSI @ 180°F)	410 SS and UHMW Polyethylene
55 Flush Mount Sensor 203mm <sup>2</sup> (8 inches <sup>2</sup> ) heavy duty	700-0207-006 remote	0.1 bar @ 82°C (1 PSI @ 180°F)	304 SS and Polyurethane
High Pressure / High Temperature (1)			
60 High Pressure & Temp.	700-0204-038 remote	137.9 bar @ 93°C (2000 PSI @ 200°F) 68.9 bar @ 260°C (1000 PSI @ 500°F)	316SS and Ceramic
61 High Temperature	700-0204-002 remote	0 bar @ 816°C (0 PSI @ 1500°F)	316SS and Ceramic
62 High Pressure & Temp.	700-0204-048 remote	275.8 bar @ 316°C (4000 PSI @ 600°F)	316SS
ZZ Sensing Element Not Listed			

**Mounting Type** (See separate Mounting Chart for first three digits)

	IL	CSL		IL	CSL
xxx1	457 mm (18")	152 mm (6")	xxxG	457 mm (18")	0 mm (0")
xxx2	305 mm (12")	152 mm (6")	xxxH	914 mm (36")	254 mm (10")
xxxA	152 mm (6")	51 mm (2")	xxxJ	914 mm (36")	0 mm (0")
xxxB	305 mm (12")	51 mm (2")	xxxK	1219 mm (48")	254 mm (10")
xxxC	305 mm (12")	89 mm (3.5")	xxxL	1524 mm (60")	254 mm (10")
xxxD	457 mm (18")	51 mm (2")	P00X	IL/CSL Other	
xxxE	457 mm (18")	89 mm (3.5")	A1BX	IL/CSL factory set for Fly Ash	
xxxF	457 mm (18")	254 mm (10")	xxxZ	Other	

Notes: CSL (Cote-Shield Length) should extend through Nozzle + Typical "Wall Buildup" + 2 Inches

- (1) Available with remote electronics only
- (2) Use A1P mounting option
- (3) Choose only sanitary mounting options
- (4) Available with 0-inch CSL only
- (5) Use P00X mounting option
- (6) Use A1B mounting option
- (7) Use A8B mounting option (1/4-inch NPT)
- (8) Choose from flange mounting only
- (9) FM approved with remote electronics only



Not all mounting options available with all sensing elements

NPT Threads		Sanitary TriClamps	
A1B 3/4"NPT	316SS	C2B 1"TriClamp	316SS
A1C 3/4"NPT	Hastelloy C	C3B 1 1/2"TriClamp	316SS
A1P 3/4"NPT	PFA	C4B 2"TriClamp	316SS
A2B 1"NPT	316SS		
A2C 1"NPT	Hastelloy C		
DIN Flanges		ANSI Flanges	
E01 25 mm 16 bar	RF 316/316L SS	DA1 1" 150#	RF 316/316L SS
EP1 25 mm 40 bar	RF 316/316L SS	DB1 1 1/2" 150#	RF 316/316L SS
EQ1 50 mm 16 bar	RF 316/316L SS	DC1 2" 150#	RF 316/316L SS
ER1 50 mm 40 bar	RF 316/316L SS	DD1 2 1/2" 150#	RF 316/316L SS
ES1 80 mm 16 bar	RF 316/316L SS	DE1 1" 300#	RF 316/316L SS
ET1 80 mm 40 bar	RF 316/316L SS	DF1 1 1/2" 300#	RF 316/316L SS
EU1 100 mm 16 bar	RF 316/316L SS	DG1 2" 300#	RF 316/316L SS
EV1 100 mm 40 bar	RF 316/316L SS	DH1 2 1/2" 300#	RF 316/316L SS
EW1 150 mm 16 bar	RF 316/316L SS	DI1 3" 150#	RF 316/316L SS
EX1 150 mm 40 bar	RF 316/316L SS	DJ1 3" 300#	RF 316/316L SS
		DK1 4" 150#	RF 316/316L SS
		DL1 4" 300#	RF 316/316L SS
		DM1 6" 150#	RF 316/316L SS
		DN1 6" 300#	RF 316/316L SS
		DA2 1" 150#	RF CS
		DB2 1 1/2" 150#	RF CS
		DC2 2" 150#	RF CS
		DD2 2 1/2" 150#	RF CS
		DE2 1" 300#	RF CS
		DF2 1 1/2" 300#	RF CS
		DG2 2" 300#	RF CS
		DH2 2 1/2" 300#	RF CS
		DI2 3" 150#	RF CS
		DJ2 3" 300#	RF CS
		DK2 4" 150#	RF CS
		DL2 4" 300#	RF CS
		DM2 6" 150#	RF CS
		DN2 6" 300#	RF CS



205 Keith Valley Road, Horsham, PA 19044 U.S.A.  
 Tel: 215-674-1234 Fax: 215 674-2731  
 Email: drexelbrook.info@ametek.com  
 Web: www.drexelbrook.com