

AN ISO 9001 REGISTERED COMPANY

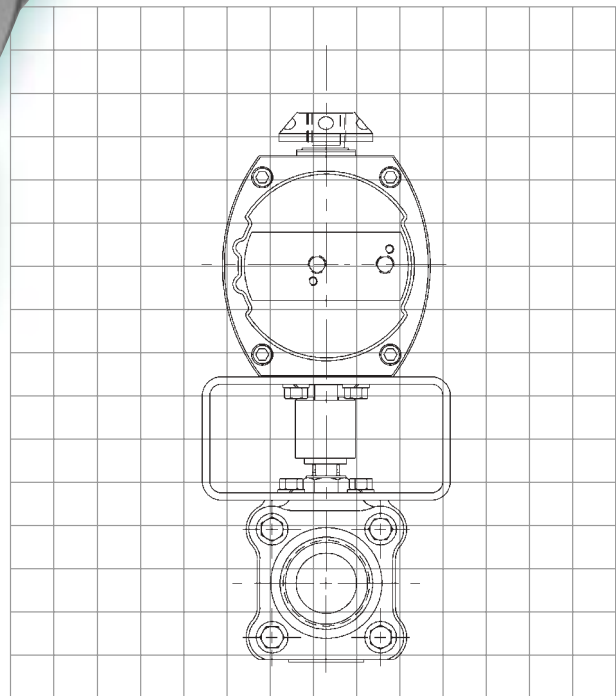

High-per Mizer[®]

Metal or resilient seated high performance ball valves capable of pressures to 1440 psi, temperatures to 1000°F.

A High Durability Ball Valve for Superheated Steam, High Temperature and Abrasive Fluid Applications.

Metal Seated Version

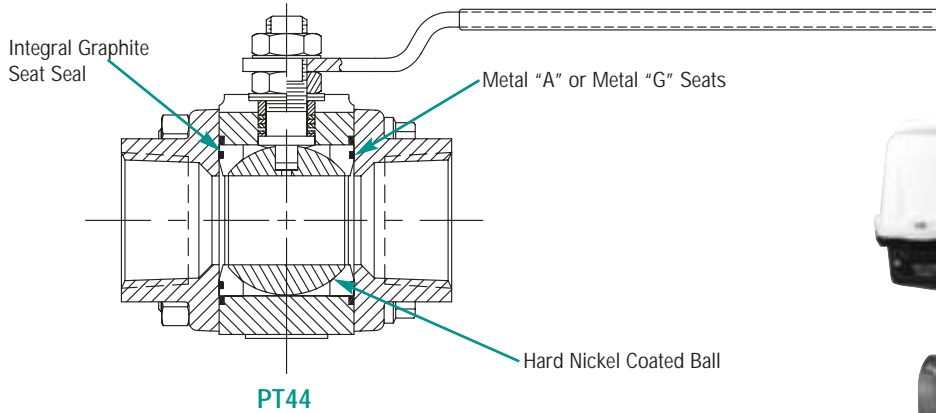

High-per Mizer advantages include:

- Ability to handle pressure and temperature shock.
- Ability to withstand high pressure drops.
- Ability to handle slurries, resist abrasion and wear.
- Bubbletight sealing to 600°F.
- Bubbletight sealing to 1440 psi.
- Ability to handle superheated steam.
- Offers leaktight integrity on thermal fluid services.
- Ability to handle a wide range of corrosives.
- Long life operation.

Metal Seated Versions feature a unique and patented seat sealing design, which incorporates an alloy stainless steel seat impregnated with self-lubricating fillers. The rigid metal seat construction is strong, highly wear and corrosion resistant, and eliminates fracturing common to graphite based seats.

The 316 stainless steel ball is nickel coated. The coating makes the ball surface harder, as well as acting as a lubricant to prevent the metal seats and ball from galling as they cycle.

Metal "A" seated versions feature a TFE impregnated stainless steel seat with integral graphite seat seal and offer temperature capability to 600°F and pressures to 1000 psi.

Metal "G" seated versions feature a graphite impregnated stainless steel seat with integral graphite seat seal and offer temperature capability to 650°F and 1000 psi.

For temperatures between 650°F and 800°F, refer to Series 94, brochure PB 94. For temperature to 1000°F consult Worcester Controls.

Resilient seated versions feature High-per Fill® seat. Proprietary to Worcester Controls, High-per Fill is a blend of polyetheretherketone, glass and graphite fillers. This blend strengthens, provides thermal resistance even at high pressures, prolongs cycle life and reduces operating torque. High-per Fill is chemically inert, has a broad corrosion compatibility and is a non-halogen (no TFE) material.



Electric Control



Pneumatic Control

It can be used in certain food, drug, tobacco and radiation services where TFE is inappropriate. The radiation resistance of High-per Fill is 2×10^9 rads.

High-per Fill will handle up to 500 psi saturated steam, temperatures to 600°F and pressure to 1440 psi, while offering bubbletight sealing.

Automation: Worcester® offers a complete line of pneumatic and electric automation packages for the High-per Mizer Valve. Refer to Brochure PB 730 for Series 75 Electric Actuators and Brochure PB 302 for Series 39 Pneumatic Actuators.

Flow Coefficient:

PT44 and PT59

Valve Size	PT44 CV	Equiv. length of Sched. 40 pipe ft.	PT59 CV	Equiv. length of Sched. 40 pipe ft.
1/4" - 3/8"	8	0.9	8	0.9
1/2"	8	3.1	32	1.4
3/4"	12	6.3	54	1.0
1"	32	3.1	105	1.9
1-1/4"	46	6.3	170	2.1
1-1/2"	82	4.3	275	2.1
2"	120	7.5	460	2.1
3"			1330	3.0
4"			2420	2.7

PT51/52 & PT44 151/301

Valve Size	CV	Equiv. length of Sched. 40 pipe ft.
1/2"	8	3.9
3/4"	12	8.7
1"	32	3.6
1-1/2"	82	3.7
2"	120	6.5
3"	350	7.1
4"	720	6.9
6"	1020	20.4

PT45

Valve Size	CV	Equiv. length of Sched. 40 pipe ft.
2-1/2"	240	5.0
3"	320	8.3
4"	580	10.4
6"	1020	20.4

Specifications

Sizes: 1/4" - 6" (depending on style)

Styles: **3-piece - Series PT44**
 1/4", 3/8", 1/2", 3/4", 1", 1-1/4", 1-1/2", 2"
3-piece - Series PT45
 2-1/2", 3", 4", 6"
3-piece - Full Port Series PT59
 1/4", 3/8", 1/2", 3/4", 1", 1-1/4", 1-1/2", 2", 3", 4"
Flanged - Series PT51 and PT52
 1/2", 3/4", 1", 1-1/2", 2", 3", 4", 6"
Wafer - Series PT44 151/301
 3", 4", 6"

***Body** Series PT44-1440 psi Class 600 ANSI
 Series PT59-1440 psi 1/4" - 2"; Class 300 - 3" & 4"
 Series PT51-Class 150 ANSI
 Series PT52-Class 300 ANSI
 Series PT44 151-Class 150 ANSI
 Series PT44 301-Class 300 ANSI
 Series PT45-Class 300

Ends Screwed, Socket Weld, Flanged ANSI 150# or
 Flanged ANSI 300#, between 150# or 300# flanges

Body Carbon Steel, 316 Stainless Steel

Stem 1/4" - 2" 17-4 pH Stainless Steel
 3" - 6" 316 Stainless Steel

Standards: For fire safe versions, refer to brochure PB FZ.
 SE valves meet ANSI B1.20.1
 Flanged valves meet ANSI B16.5, B16.10
 Flanged and 1/4" - 2" 3-piece valves meet ANSI B16.34 (600 # class) when hydro test is specified.

Operation: Manual lever handle. Electric or Pneumatic actuator available.

Dimensions: Refer to individual product catalogs; PB401 (44), PB45 (45), PB 451 (59), PB51 (51/52), SB502 (151/301) or dimensional sheets EVD 1-4.

	METAL SEATED	METAL SEATED	RESILIENT SEATED
Seats:	Metal "A" TFE impregnated stainless steel with integral graphite seat seal	Metal "G" Graphite impregnated stainless steel with integral graphite seat seal	High-per Fill "X" Proprietary blend of PolyEtherEther-Ketone, glass and graphite fillers
Body Seals:	Refer to How to Order Table	Refer to How to Order Table	Refer to How to Order Table
Stem Seal(s):	Polyfill®/PEEK	Polyfill/PEEK	Graphite/PEEK
Thrust Bearing:	Polyfill/PEEK	Polyfill/PEEK	PEEK
Ball:	316 S.S. Nickel coated	316 S.S. Nickel coated	316 S.S.
Max. Temp:	600°F	650°F	600°F
*Max. Pressure: (Seats & Seals)	1000psi	1000psi	1440psi
Leakage Rate:	Bubbletight	ANSI Class VI	Bubbletight
Steam Service:	For steam service, refer to Worcester Steam Service Data Sheet (SSD) for ratings. This data sheet is found in the Engineering section of the general catalog binder.		

High Temp: For applications to 1000°F, contact Worcester Controls Custom Products.

*Refer to body ratings, seat and seal ratings and pressure-temperature ratings to determine maximum safe pressure and temperature for the High-Per Mizer valve.

NOTE: Standard Worcester valves are assembled with silicone based break in lubricant. For other options consult your distributor or Worcester Controls.



Pressure/Temperature Ratings

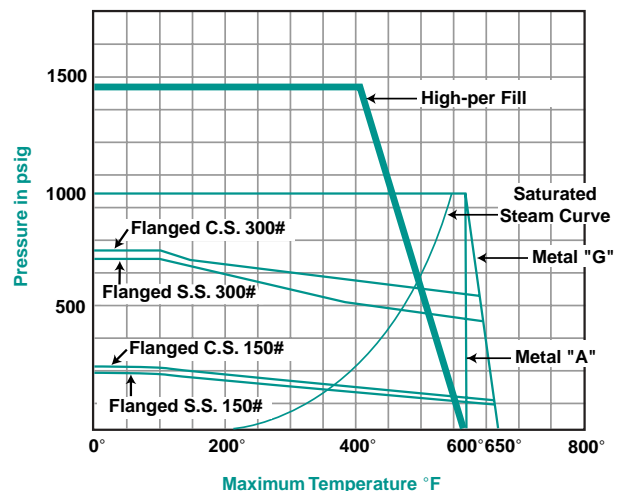



PT44/PT59
1/4" - 2"

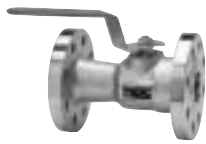

PT51/PT52
1/2" - 2"



PT51/PT52
3" - 6"



PT44 151/301
3" - 6"



PT45
2-1/2" - 6"
PT59
2" - 4"

How to Order

Valve Size	Product Series	Body Pipe Ends	Ball & Stem	*Seats	*Body Seals	End Connection	Variations
1/4" - 2"	PT 44 - 3-piece	4 - Carbon Steel 6 - 316 S.S.	6 - Stainless Steel	G - Metal "G"	G - Graphite 316 S.S. "S" gasket	SE - Screw End Carbon Steel, 316S.S. SW - Socket Weld Carbon Steel, 316L S.S.	V 3* - Upstream Relief Hole V 5 - Hydrostatic Testing V 6 - Source Inspection V14 - Handleless Valve V32 - Oval Handle V36 - Cert. of Compliance V37 - Cert of Comp.& Hydro testing
1/4"-1-1/2"	PT 59 - Fullport 3-piece			A - Metal "A" X - High-per Fill	G - Graphite coated 316 S.S. "S" gasket M - TFE coated 316 S.S. "S" gasket		V46 - Silicon Free Lubricant (not used with Metal "A" or "G" seats) V48 - Extended Lever Handle 1/4" - 2" PT 44, PT 51/52 1/4" - 1-1/2" PT 59 only
1/2" - 2"	PT 51/PT 52 Flanged 150#/300#	4 - Carbon Steel 6 - 316 S.S.	6 - Stainless Steel	A - Metal "A"	M - TFE coated 316 S.S. "S" gasket	150 - ANSI 150# flanges 300 - ANSI 300# flanges	V51* - High Cycle Stem Build V58* - B16.34 Compliance V59 - Extended Oval Handle 1/4" - 2" PT 44, PT 51/52 1/4" - 1-1/2" PT 59 only
2"	PT 59 - Fullport 3-piece	4 - Carbon Steel 6 - 316 S.S.	6 - Stainless Steel	A - Metal "A" G - Metal "G" X - High-per Fill	Z - Graphite (4 bolt R3)	SE - Screw End Carbon Steel, 316S.S. SW - Socket Weld Carbon Steel, 316L S.S.	V60 - Osha Lockout 1/4" - 2" PT 44 1/4" - 1-1/2" PT 59 only
3" - 4" 2-1/2" - 6"	PT 59 - Fullport 3-piece PT 45 - 3-piece	4 - Carbon Steel 6 - 316 S.S.	6 - Stainless Steel	A - Metal "A" G - Metal "G" X - High-per Fill	G - Graphite Laminated 316 S.S. gasket	SE - Screw End Carbon Steel, 316S.S. SW - Socket Weld Carbon Steel, 316L S.S.	V66 - Cert. of Compliance European Valve Orders V67* - Weld in-place Valves (3-piece valve only) V72 - Cert. of Compliance for European Pressure Equipment Directive Conformance.
3" - 6"	PT 44 - 151/301	4 - Carbon Steel 6 - 316 S.S.	6 - Stainless Steel	A - Metal "A" G - Metal "G" X - High-per Fill	T - TFE (PT44 with "A" seat only) Z - Graphite	151 - for use between 150#ANSI flanges 301 - for use between 300# ANSI flanges	Leave blank if no variations.
3" - 6"	PT 51/PT 52 - Flanged 150#/300#					150 - ANSI 150# flanges 300 - ANSI 300# flanges	

****VARIATION NOTES:**

V3 - Not used with Metal "A" or "G" Seats.
V51 - Not used on 1/4" - 2" PT 44, 1/2" - 2" PT 51/PT 52, 1/4" - 1-1/2" PT 59, or 3" - 6" PT 44, PT 51/PT 52 valves with metal "G" seats, or 2" - 6" 3-piece valves with "G" or "X" seats.
V58 - Not offered on 2" - 4" PT 59, PT 45, or PT 44 151/301 valves.
V67 - Not used on 2" - 4" PT 59 and 2-1/2" - 6" PT 45 with "X" seats.
S7 - Complete S.S. trim option for 3" - 6" PT 44, PT 51/PT52 only. Wrench block and extension, hexhead bolt, retaining nut, stop, stop screw and Belleville washer(s) or spacer if used.
Ordering Example: 1-1/2" High-Per Mizer with S.S. body, Screw ends, Ball & Stem, Metal "G" Seats and Graphite coated S.S. "S" gasket.

*NOTE: AM Seat & Seal combination available for screw end only in sizes 1/4" - 2" 3-piece valves.

CAUTION: Ball Valves can retain pressurized media in the body cavity when closed. Use care when disassembling. Always open valve to relieve pressure prior to disassembly. Due to continuous development of our product range, we reserve the right to alter the dimensions and information contained in this leaflet as required.

Worcester® is a registered trademark of Worcester Controls. • Polyfill® is a registered trademark of Worcester Controls.
High-Per Mizer® and High-Per Fill® are registered trademarks of Worcester Controls. • Worcester Controls® is a registered trademark of Flowserve Corporation.

Flowserve Corporation has established industry leadership in the design and manufacture of its products. When properly selected, this Flowserve product is designed to perform its intended function safely during its useful life. However, the purchaser or user of Flowserve products should be aware that Flowserve products might be used in numerous applications under a wide variety of industrial service conditions. Although Flowserve can (and often does) provide general guidelines, it cannot provide specific data and warnings for all possible applications. The purchaser/user must therefore assume the ultimate responsibility for the proper sizing and selection, installation, operation, and maintenance of Flowserve products. The purchaser/user should read and understand the Installation Operation Maintenance (IOM) instructions included with the product, and train its employees and contractors in the safe use of Flowserve products in connection with the specific application.

While the information and specifications contained in this literature are believed to be accurate, they are supplied for informative purposes only and should not be considered certified or as a guarantee of satisfactory results by reliance thereon. Nothing contained herein is to be construed as a warranty or guarantee, express or implied, regarding any matter with respect to this product. Because Flowserve is continually improving and upgrading its product design, the specifications, dimensions and information contained herein are subject to change without notice. Should any question arise concerning these provisions, the purchaser/user should contact Flowserve Corporation at any one of its worldwide operations or offices.

For more information about Flowserve Corporation, contact www.flowserve.com or call USA 1 800 225 6989.

FLOWSERVE CORPORATION
FLOW CONTROL DIVISION
1978 Foreman Drive
Cookeville, Tennessee 38501 USA
Phone: 931 432 4021
Facsimile: 931 432 5518