



FLOW METERING EQUIPMENT



COIN

Flow Meters



Segmented Wedge

Your First Choice in Intelligent Flow Management...

COIN Flowmeter

The Preso COIN Flowmeter accommodates most flows, even the most abrasive. Accuracy and reliability are achieved by its rugged construction, practical design, and simple principle of operation. It stands alone in its ability to maintain the necessary square root relationship between flow rate and differential pressure for almost any type of flow:

- **Clean Liquids**
- **High Viscosity Fluids**
- **Steam**
- **Slurries**
- **Corrosive Processes**
- **Gas/Air**



Even viscosity up to 3,000 centipoise does not affect the accuracy of the COIN flowmeter. The flow coefficient stays highly predictable down to the remarkably low Reynolds number of 300. This makes the series COIN flowmeter ideal for such traditionally difficult-to-meter applications as fuel oil, waste water, coal tar, iron ores, black liquor, and others.

Preso COIN Principle of Operation

The basic flow equation for the COIN series is derived from BERNOULLI'S THEOREM (energy balance and the continuity equations). An engineered restriction creates a differential pressure that equates to a mass or volumetric rate of flow. Different height (H) over diameter (D) ratios are specified to handle different flow ranges.

A COIN flowmeter can solve your most difficult flow measurement applications. You get accurate, reliable results from the COIN flowmeter.

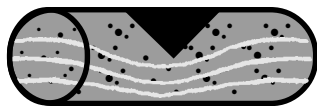

Abrasive, Erosive Slurries

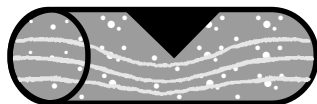

Multiphase Flows

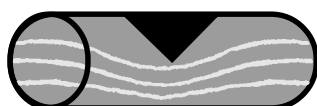

Viscous, Dirty Fluids



Clean Fluids, Steam, Gas, Air

- Simple principle of operation allows functionality on any fluid.
- Long life without maintenance. Does not foul.
- Minimal upstream and downstream piping requirements.
- Low permanent pressure loss.

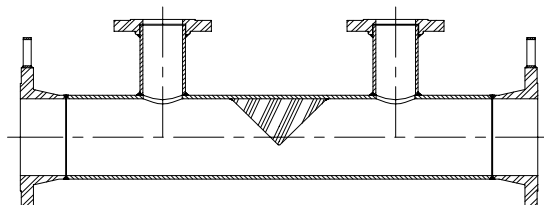

- Sizes: 1/2" to 48"
- Different H/D (opening) Ratios
- Fabricated to standards such as: API, ASME, ANSI, B 31.1, and CSA-Z299.3 or equivalent.
- Manufactured to ISO - 9001 quality standards.



Characteristics

- Accuracy: $\pm 0.5\%$ of readings (calibrated)
 $\pm 3\%$ of readings (uncalibrated)
calibrated at CEESI, Alden, NRCC, NIST traceable laboratories
- Mass flow output with multivariable transmitter (accuracy $\pm 0.5\%$ calibrated)
- Repeatability: $\pm 0.2\%$ of readings
- Turndown Ratio: 10/1
- Very low Reynolds number measurements (down to RE # 300)
- Low Pressure Losses
- Reduced Pumping Costs
- Very high viscosity measurements (500, 1000, 3000 centipoise and higher)
- Resists wear, maintenance free (no moving parts)
- Short form, lighter weight than classical venturi meters
- Bi-Directional flow measurement
- Easily installed in any position with minimal straight pipe requirements (5 pipe diameters upstream and 2 pipe diameters downstream)
- Sizes 1/2" to 48" and larger upon request
- Manufactured to standards such as: ASME, ANSI B31.1, NACE MR-0175 and CSA-Z299.3 or equivalent
- ISO-9001 certified design and fabrication

Typical COIN Meter

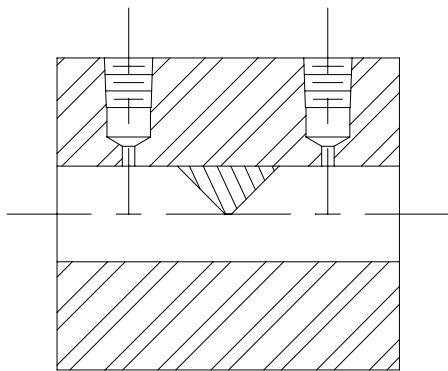

(A) WAFER

(Mounted between 150, 300 Lbs. ANSI B16.5 Flanges)

NPT Pressure Taps

(B) NPT

(NPT Pressure Taps/NPT Process Connection)

(C) Butt Weld

(NPT Pressure Taps/Butt Weld Process Connection)

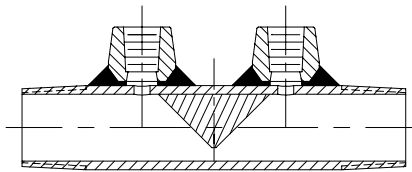

Model: COIN-NW (A)

COIN-NN (B)

COIN-NB (C)

Sizes: 1/2" - 3"

Materials: CS, SS, or others

Pressure Ratings:

300 PSI (A)

1000 PSI (B, C)

Temperature Ratings:

200°F (A)

400°F (B, C)

Pipe Schedules:

10, 40, 60, 80, or others

Instrument Valves: Optional

(CS, SS, or others)

Calibration: Optional

(Water, oil, air, viscous, or others)

ID-Tag: 316-SS

Flanged Process Connection

NPT Pressure Taps

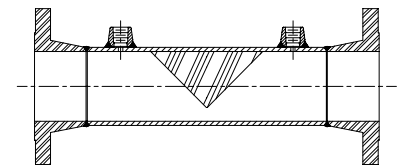

Model: COIN-NF

Sizes: 1/2" - 48"

Materials: CS, SS, or others

Flanges: ANSI-B 16.5
(150, 300, 600, 900 Lbs., or higher ratings)

Pressure /Temperature Ratings:
Dependent on flange ratings

Pipe Schedules:
10, 40, 60, 80 or others

Instrument Valves: Optional
(CS, SS, or others)

Calibration: Optional
(Water, oil, air, viscous, or others)

Lifting Lugs:
same as construction materials

ID-Tag: 316-SS

Configurations . . .

Flanged Process Connection

Flanged Pressure Taps

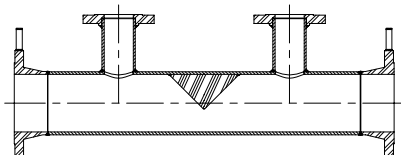

(Remote Seal Transmitter Mount)

Model: COIN-FF

Sizes: 1/2" - 48"

Materials: CS, SS, or others

Flanges: ANSI-B 16.5
(150, 300, 600, 900 Lbs.,
or higher ratings)

Pressure/Temperature Ratings:
Dependent on flange ratings

Pipe Schedules:
10, 40, 60, 80, or others

Calibration: Optional
(Water, oil, air, viscous, or others)

Lifting Lugs:
same as construction materials

ID-Tag: 316-SS

Chemical-Tee Pressure Taps

Flanged Process Connections

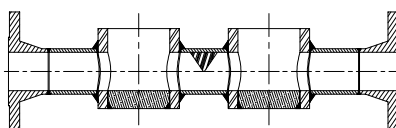

(Remote Chem Seal
Transmitter Mount)

Model: COIN-Chem

Sizes: 1/2" - 48"

Materials: CS, SS, or others

Flanges: ANSI-B 16.5
(150, 300 Lbs.)

Pressure Ratings: Max 300 PSI

Temperature Ratings:
800°F or dependent on flange ratings

Pipe Schedules:
10, 40, 60, 80, or others

Calibration: Optional
(Water, oil, air, viscous, or others)

Lifting Lugs:
same as construction materials

ID-Tag: 316-SS

Flanged Process Connections

Integral Transmitter Mount Taps

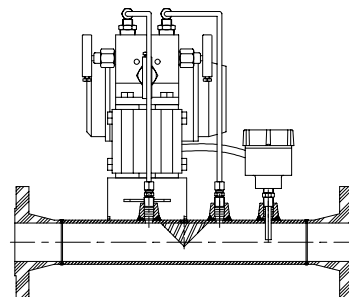

Model: TransCOIN
(Integral Standard Transmitter Mount)

Model: MassCOIN
(Integral Multi-Variable Transmitter
Mount and Temperature Sensor)

Sizes: 3" - 48"
Materials: CS, SS, or others

Flanges: ANSI-B 16.5
(150, 300, 600, 900 Lbs.,
or higher ratings)

Pressure Ratings: 1500 PSI

Temperature Ratings: 300°F

Pipe Schedules:
10, 40, 60, 80 or others

Calibration: Optional
(Water, oil, air, viscous, or others)

Lifting Lugs:
same as construction materials

ID-Tag: 316-SS

Engineering Data

Differential Pressure Calculation

The basic flow equations for the PRESO COIN Meter or Wedge are derived from the Bernoulli's Theorem (Energy Balance), and the Continuity Equation. The most common equations used by the industry, where different units are employed according to the flowing conditions of each type of fluid as follows:

(i) Liquid

$$\Delta P = \left(\frac{\text{GPM}}{C_1} \right)^2 * SG_F \quad C_1 = 5.6660 * K * D_i^2 * F_a$$

(ii) Gas / Air

$$\Delta P = \left(\frac{\text{SCFM}}{C_1} \right)^2 * \frac{SG_s(T_f + 460)}{P_f} \quad C_1 = 128.8 * K * D_i^2 * F_a$$

Note: SCFM = ACFM * $\frac{P_f}{14.73} * \frac{520}{T_f + 460}$

(iii) Steam

$$\Delta P = \left(\frac{\text{Lbs/Hr}}{C_1} \right)^2 \quad C_1 = 359 * K * D_i^2 * F_a * \sqrt{\rho_f}$$

Where

- ΔP - Differential Pressure; Inches of water column at 60°F
- GPM - US Gallons per Minute
- SCFM - Standard Cubic Feet per Minute at 60°F and 14.73 psia
- ACFM - Actual Cubic Feet per Minute
- Lbs/Hr - Pounds Mass per Hour
- C1 - Flow Constant
- K - Flow Coefficient
- Di - Inside Pipe Diameter, Inches
- Fa - Thermal Expansion of the Pipe; 1 up to 100°F/1.001-1.005 (100-500°F)
- Tf - Flowing Temperature, °F
- Pf - Flowing Pressure, psia
- SGf - Specific Gravity at Flowing Conditions
- SGs - Specific Gravity at Standard Conditions (60°F, 14.73 psia)
- ρ_f - Flowing Density, lbs/ft³

Typical Capacity Tables (100 ΔP H₂O)

(For Reference only)

(1) Water (GPM)		COIN-2 (Ratio 0.3)	COIN-3 (Ratio 0.4)	COIN-4 (Ratio 0.5)
Pipe Size	2"	45	70	100
	6"	400	600	850
	12"	1520	2250	3140
	20"	3740	5575	7580
(2) Air (SCFM) 100 PSI/60°F		COIN-2 (Ratio 0.3)	COIN-3 (Ratio 0.4)	COIN-4 (Ratio 0.5)
Pipe Size	2"	485	735	1100
	6"	4165	6400	9000
	12"	16130	24000	33500
	20"	39800	59400	80730
(3) Steam (Lbs/hr) Saturated, 100 PSI		COIN-2 (Ratio 0.3)	COIN-3 (Ratio 0.4)	COIN-4 (Ratio 0.5)
Pipe Size	2"	1470	2220	3245
	6"	12600	19250	27100
	12"	48700	72200	100000
	20"	120000	180000	245000

Water Test

Calibration of a 16: COIN (Wedge) Meter
Model COIN-16-4, 16" Sch. 40 pipe, I.D.: 15"
Alden Research Laboratory Inc., August 8, 1995, ARL No. C95-7785RD

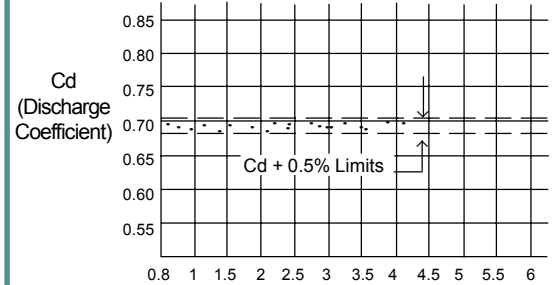

Re # (Million)
Reynolds Number (based on pipe Diameter) X 10⁶
Discharge Coefficient (Cd) ± 0.5%

Oil Test (Viscosity: 10 Centipoise-Cp)

Flow Dynamics Inc., August 8, 2000, FD No. 8960

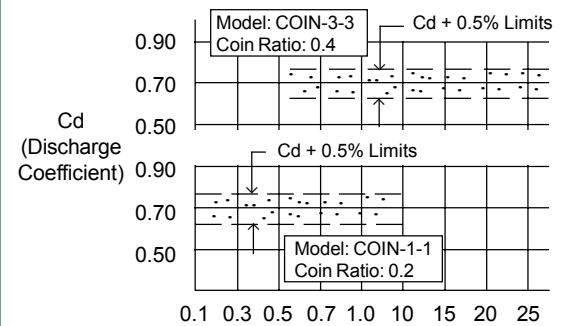

Re # (X 10⁴)
Reynolds Number (based on pipe Diameter) X 10⁴
Discharge Coefficient (Cd) ± 0.5%

Flow Coefficient (K)

COIN Models: NPT or Flanged Taps				
Pipe Size (Inches)	COIN-1 (Ratio 0.2)	COIN-2 (Ratio 0.3)	COIN-3 (Ratio 0.4)	COIN-4 (Ratio 0.5)
1/2"	0.1137	0.1990	0.3076	0.4627
3/4"	0.1104	0.1954	0.3074	0.4454
1"	0.1072	0.1917	0.3074	0.4280
1 1/4"	0.1074	0.1923	0.2925	0.4190
1 1/2"	0.1076	0.1929	0.2778	0.4101
2"	0.1098	0.1896	0.2860	0.4173
2 1/2"	0.1041	0.1846	0.2832	0.4180
3"	0.0984	0.1795	0.2805	0.4188
4"	0.1086	0.1876	0.2918	0.4257
6"		0.1876	0.2882	0.4051
8"		0.1853	0.2873	0.4019
10"		0.1863	0.2809	0.3944
12"		0.1875	0.2778	0.3889
14"		0.1885	0.2819	0.3842
16"		0.1849	0.2795	0.3784
18"		0.1848	0.2756	0.3764
20"		0.1862	0.2780	0.3778

Pressure Loss

Permanent Pressure Loss (PPL)
(% of Meter Differential)

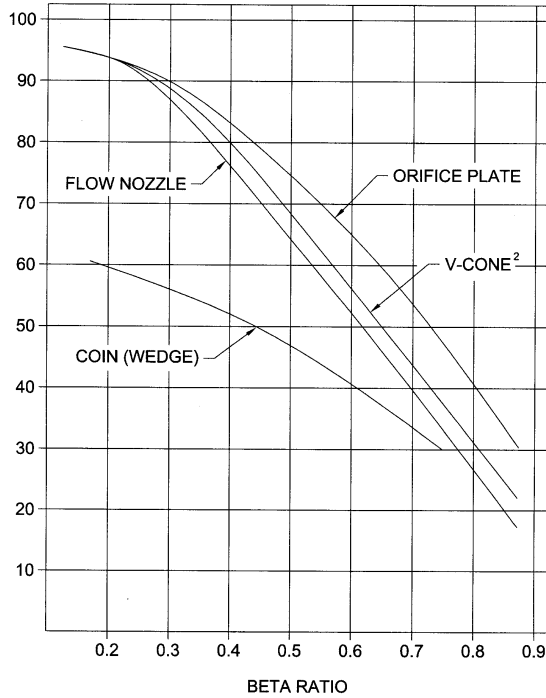

MODEL	H/ID	EQUIVALENT BETA ¹	% BLOCKAGE
COIN-1	0.2	0.3770	80%
COIN-2	0.3	0.5020	70%
COIN-3	0.4	0.6110	60%
COIN-4	0.5	0.7070	50%

¹ MILLER, R.W., FLOW MEASUREMENT ENGINEERING HANDBOOK, 3RD EDITION, McGRAW-HILL, 1996

² McCROMETER, HEMET-CALIFORNIA

Energy Cost

COIN (Wedge) meters have lower permanent pressure losses (PPL) than orifice plate, V-CONE®, or Flow-Nozzle (See graph above).

Typical Energy Calculation:

1. Liquid

$$\text{HP (Horsepower)*} = \frac{\text{PPL} \times \text{GPM}}{47,500 \times \text{Efficiency}(80\%)}$$

2. Gas

$$\text{HP (Horsepower)*} = \frac{\text{PPL} \times Z_c \times \text{Compressibility} \times T_c \times \text{SCFH}}{13.5 \times 10^6 \times P_c \times \text{Efficiency}(80\%)}$$

3. Steam

$$\text{HP (Horsepower)*} = \frac{\text{PPL} \times \text{Lbs/Hr}}{3.8 \times 10^5 \times P_c \times \text{Efficiency}(80\%)}$$

Energy Cost (\$0.05/Kwh Industrial Average)*

$$0.75 \times \text{HP} \times 8760 \text{ (hours/year)} \times \$0.05 \text{ (Kwh)}$$

* Miller, R. W., Flow Measurement Engineering Handbook, 3rd Edition, McGraw-Hill, 1996

Installation Instructions

1 - ORIENTATION

The COIN Meter can be installed vertically or horizontally. For best performance; on horizontal installation; the COIN element should be installed 90° along the pipe center line (Fig. 1)

* For vertical installation; attention must be made to zeroing the transmitter due to the slight hydrostatic head effect (Fig. 2)

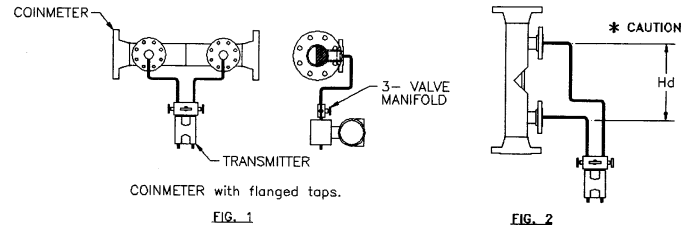

NOTES:

- Other Positions are acceptable with proper venting.
- Connections between the COIN Meter and the transmitter should be 3/8" tubing minimum.
- The use of a 3-valve manifold is recommended for zeroing the transmitter.

2 - INSTALLATION

Install so that the flow arrows are in the correct direction of flow. Although the COIN Meter is bi-directional, the high pressure connection is always facing the flow.

3 - PERFORMANCE AND ACCURACY

For best performance and accuracy, minimum upstream and downstream lengths are required. See Table 1 for minimum lengths.

Installation Requirements

Table 1

DISTANCES (DIMENSIONS A & B) EXPRESSED IN NOMINAL PIPE DIAMETERS	DIMENSION	ACCURACY: CALIBRATED ±0.5% UNCALIBRATED ±3%			
		COIN RATIO (H/ID.)			
UPSTREAM DISTURBANCE		.2	.3	.4	.5
Single Elbow	A	7	9	10	12
	B	4	4	4	4
Two elbows in the same plane	A	10	12	14	16
	B	4	4	4	4
Two elbows in different planes	A	20	22	24	30
	B	4	4	4	4
Reducer	A	9	11	14	16
	B	4	4	4	4
Expander	A	9	10	12	14
	B	5	5	5	5
Tee connection with different diameters	A	7	9	10	12
	B	4	4	4	4
Globe valve fully opened	A	10	12	14	16
	B	4	4	4	4
Gate valve fully opened	A	7	7	9	10
	B	4	4	4	4

NOTES:

- For upstream and downstream lengths equal to one half the values shown add 1 percent to the Accuracy Value.
- Any flow conditioner shall be installed in the straight length between the primary element and the upstream distance, or the fitting closest to the element. The straight lengths between fitting and conditioner shall be at least 10D and the length between conditioner and Coin Meter shall be at least 15D.
- For other fittings, configurations, consult the factory.

Typical Specifications

General:

Furnish and install as shown on the drawings a flow element of the segmented or segmental wedge design differential pressure type as manufactured by Preso Meters Corporation.

Configuration:

The inlet section shall be of the same diameter as the incoming pipe section and followed by a precise segmented single piece construction angled section equal on both sides for bidirectional flow measurement. The H/D ratio shall be determined by the manufacturer according to recognized standards and formulas. The discharge coefficient (Cd) shall be linear and stable in the operating flow range.

Materials:

The construction material, instrument connections, instrument valves or instrument flange connections and end connections shall be selected to meet intended service conditions. Identification tag shall be provided as required.

Accuracy & Repeatability:

The accuracy of the COIN meter shall be within $\pm 3.0\%$ (uncalibrated) and $\pm 0.5\%$ (calibrated) with a repeatability of $\pm 0.2\%$ and turndown of 10:1 in the corresponding and appropriate range of Reynolds' Numbers. For custody transfer applications the COIN meter shall be flow tested by an independent NIST certified laboratory under the design operating conditions and piping configurations.

Quality:

All COIN meters shall be manufactured under an ISO 9001 certified quality program. Certification documentation shall be available for inspection. The manufacturer shall provide a Flow Calculation Data Sheet with standard data and formulas for approval by the design engineer.

Other Preso Products to Meet Your Needs...

PRESO METERS CORPORATION is a fully integrated manufacturer of quality, precision engineered primary flow elements serving the industrial, commercial and municipal markets for the last twenty-five (25) years. PRESO elements are based on a proven scientific principle of flow measurement through accurate differential pressure readings to obtain flow rate information.



PRESO annular devices, with the patented "ELLIPSE" self-averaging pitot tube are designed to measure liquids, gases and steam flows.



PRESO's complete line of VENTURI; "Classical", Venturi-Nozzle" and "Low-Loss" offer unparalleled accuracy and reliability, which surpasses industry standards.



8635 Washington Ave., • Racine, WI 53406
Tel.: (262) 639-6770 • Fax: (262) 639-2267
Toll Free: (800) 632-7337
www.preso.com • info@preso.com

Ellipse
FORM # 4-25-04
Rev. 1 7-2003