

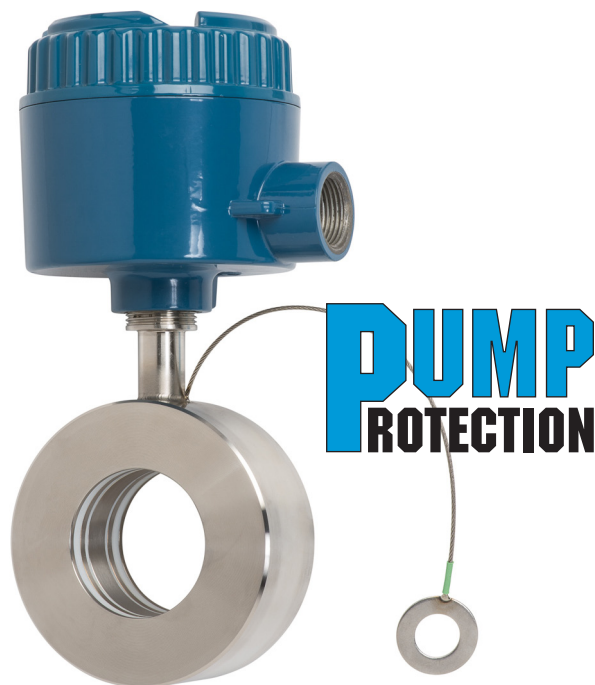

## Clear Line™ In-Line Fluid Detector



### No Maintenance

Cote-Shield™ circuitry ensures dependable detection regardless of conductive coatings or product build-up on the sensor.

### Easy to Install

The wafer style sensing element mounts directly into existing pipelines between two standard 150-lb. flat-faced flanges.

### Simple Operation

Factory calibrated. No need for field adjustments, even with variations in product temperature, density or conductivity. No routine maintenance required.

### Low Level/Interface Detection

The Drexelbrook Clear Line In-Line Fluid Detector is ideally suited for empty pipe and tank applications in hydrocarbon, pharmaceutical, chemical, and food processing facilities. This reliable instrument monitors the presence or absence of fluid in a pipe for complete assurance that the tank is empty. It can also be used for interface detection to accurately determine when material changes from one phase to another. This is especially useful in processes involving materials separation.

### Perfect for Shear-Sensitive Products

The ultra-smooth surface of the Clear Line is ideal for shear-sensitive products. Easily mounted between flat-faced flanges the Clear Line does not interfere with product flow in any way.

### No Recalibration Required

Each Clear Line detector is factory-calibrated to provide reliable, repeatable performance regardless of changes in process fluids and coatings, or variations in temperature, conductivity, and density. It works without recalibration on processes where fluids can vary from organics to caustics.

### Electronic Options

Drexelbrook offers two remote-mounted electronics options for the Clear Line In-Line Fluid Detector.

- For applications with low to moderate coating conditions and requiring Hazardous Location Approvals, use RXX (Intellipoint™) electronics.
- For applications with heavy coating conditions but do not require approvals, use Super Cote-Shield™ electronics.
- Consult factory for additional options.



# Clear Line™ In-Line Fluid Detector

## SPECIFICATIONS

### Electronics

#### Power requirement:

- 120 ± 25 Vac, 50/60 Hz, 1 watt
- 240 ± 50 Vac, 50/60 Hz, 1 watt (optional)
- 12-30 Vdc 1 watt (optional)

#### Ambient temperature:

-40°F to 140°F (-40°C to 60°C)

#### Level Output:

DPDT relay

#### Contact Rating:

- 120 Vac; 5A non-inductive, 3 A inductive
- 230 Vac; 5A non-inductive, 2 A inductive
- 24 Vdc; 5A non-inductive
- Min. Rating 100mA / 12VDC

#### Time Delay:

Adjustable 0-120 sec, for pump start/stop.

#### Fail-safe

Empty-pipe fail-safe (factory set); relay will de-energize, indicating empty pipe upon loss of power.

#### RFI Protection (built in):

The operating point for unit in housing is unaffected by 5W field @ 27 MHz, 150 MHz, or 450 MHz at a distance of 5 ft. from exposed sensor, cable, or power line.

#### Sensor

#### Process Temperature and Pressure:

250°F @ 100 PSI (121°C @ 7 bar)

#### Material Compatibility:

Process-wetted parts: 316L SS & TFE

#### Mounting - VERTICAL ONLY:

Sensor must be mounted in a vertical run of pipe or sloping pipe run to provide material drainage

## DIMENSIONS

### Remote

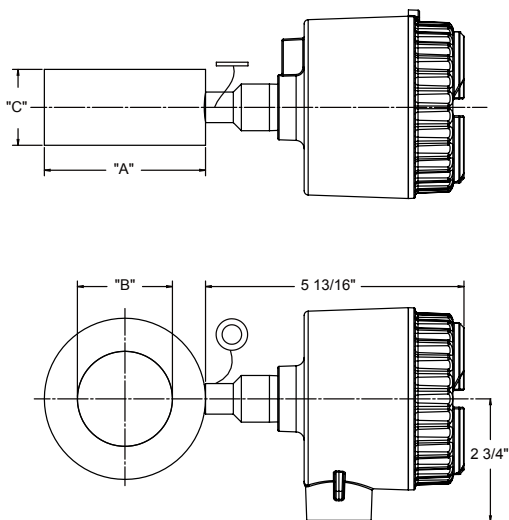

### Integral

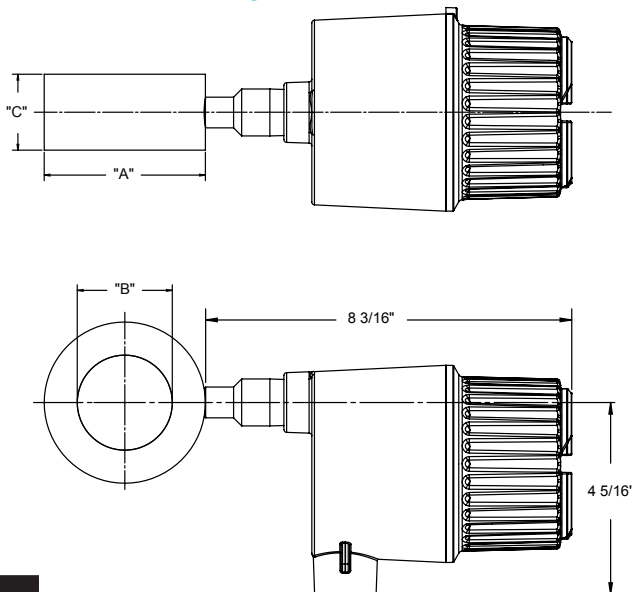

Pipe Size	O.D. "A"	I.D. "B"	Width "C"
2	3.63" (92mm)	2.14" (54mm)	1.69" (43mm)
3	5.00" (127mm)	3.15" (80mm)	2.13" (54mm)
4	6.19" (157mm)	4.12" (105mm)	2.38" (61mm)
6	8.50" (216mm)	6.20" (158mm)	2.94" (75mm)

- Wafer style sensing element mates with ANSI 150 lb flanges in nominal pipe sizes as noted.
- "B" dimension is slightly larger than schedule 40 nominal pipe I.D.